



THE UNIVERSITY OF  
**NEWCASTLE**  
AUSTRALIA

**The University of Newcastle**  
Infrastructure and Facilities Services  
Project Briefing Document  
**Fire Services**  
Guiding Principles

October 2022  
*Version 1.3*

<b>Document Revisions</b>					
<b>Revision</b>	<b>Date</b>	<b>Description</b>	<b>Prepared by:</b>	<b>Checked by:</b>	<b>Approved by:</b>
1.1	29/05/2020	Preliminary Revision	Leigh Shepherd Peter Digby	Mark Mazzitello	Mark Mazzitello
1.2	14/01/2021	Additional information and details and formatting update	Leigh Shepherd Peter Digby	David Alexander	Tim Dale
1.3	10/10/2022	Additional information and details Fibre Network, Q Building and Mass Notification System.	Peter Digby		

<b>Revision Summary</b>	
<b>Revision</b>	<b>Change summary</b>
1.1	Preliminary Revision and Format Changes
1.2	Inclusion of Proposed Fibre Network and Format Changes
1.3	Inclusion of Fire Rated Fibre Network Q Building ASE Mass Notification System (VOIP) using BARIX

## Contents

1	PURPOSE.....	6
2	SCOPE.....	6
2.1	NEW BUILDINGS.....	8
2.2	EXISTING BUILDINGS.....	8
3	GLOSSARY OF TERMS.....	9
4	AUTHORITIES AND RESPONSIBILITIES.....	10
5	TECHNICAL REQUIREMENTS.....	10
5.1	GENERAL.....	10
5.2	DESIGN AND CONSTRUCT CONTRACTS.....	12
5.3	FIRE SYSTEM MANAGEMENT (FMS).....	13
5.4	ACCESS PANELS, DOORS & HOPPERS TO FIRE RESISTING SHAFTS.....	17
5.5	AUTOMATIC FAIL-SAFE DEVICES.....	17
5.6	AUTOMATIC FIRE DETECTION AND ALARM SYSTEMS.....	18
5.7	AUTOMATIC FIRE SPRINKLER SYSTEMS.....	23
5.8	EMERGENCY LIFTS.....	25
5.9	EMERGENCY LIGHTING.....	25
5.10	EMERGENCY WARNING AND INTERCOMMUNICATION SYSTEM (EWIS).....	25
5.11	EMERGENCY EVACUATION DIAGRAMS.....	28
5.12	EXIT SIGNS.....	28
5.13	FIRE DAMPERS.....	29
5.14	FIRE / EGRESS DOORS.....	29
5.15	FIRE HOSE REEL SYSTEMS.....	30
5.16	FIRE HYDRANT SYSTEMS.....	31
5.17	FIRE SEALS PROTECTING OPENING IN FIRE RESISTANT COMPONENTS.....	32
5.18	FIRE SHUTTERS.....	33
5.19	GASEOUS FIRE SUPPRESSION SYSTEMS.....	33
5.20	LIGHTWEIGHT FIRE RATED CONSTRUCTION.....	33
5.21	MECHANICAL AIR-HANDLING SYSTEM SHUTDOWN.....	34
5.22	PORTABLE FIRE EXTINGUISHERS & FIRE BLANKIETS.....	34
5.23	PRESSURISING SYSTEMS.....	35
5.24	REQUIRED POWER OPERATED EXIT DOORS.....	35
5.25	SMOKE & HEAT VENTS.....	36
5.26	SMOKE & HEAT ALARM SYSTEMS.....	36
5.27	SMOKE DAMPERS.....	36

5.28	SMOKE DOORS.....	36
5.29	STANDBY POWER SYSTEMSTANDBY POWER SYSTEMS .....	37
5.30	WALL WETTING SPRINKLER & DRENCHERS SYSTEMS.....	37
5.31	WARNING & OPERATIONAL SIGNS .....	38
5.32	EQUIPMENT LABELLING AND IDENTIFICATION.....	38
5.33	PIPEWORK AND CABLING INSTALLATIONS .....	38
6	COMMISSIONING.....	39
7	SAFETY IN DESIGN.....	40
8	DOCUMENTATION & RECORDS .....	40
8.1	DESIGN DOCUMENTATION .....	40
8.2	COMPLETION DOCUMENTS .....	41
9	OPERATIONS .....	41
9.1	MATERIALS AND EQUIPMENT SELECTION .....	41
9.2	SERVICE ACCESS REQUIREMENTS .....	42
9.3	REDUNDANT EQUIPMENT.....	42
9.4	INTERRUPTION TO ESSENTIAL FIRE SAFETY MEASURES .....	42
9.5	MAINTENANCE & TESTING.....	43
10	AUTHORISATION OF VARIATIONS.....	44
11	QUALITY CONTROL.....	44
11.1	DESIGN STANDARD COMPLIANCE.....	44
11.2	DESIGN STANDARD CERTIFICATION .....	44
11.3	CONSTRUCTION COMPLIANCE.....	44
11.4	ACCEPTANCE .....	45
12	ACKNOWLEDGEMENTS.....	45
13	REFERENCES.....	46
14	ATTACHMENTS .....	47
ATTACHMENT 1	DESIGN AND CONSTRUCT CHECKLIST FOR CONSULTANTS.....	48
ATTACHMENT 2	CALLAGHAN FIRE SYSTEM NETWORK TOPOLOGY (FIP LOOPS) .....	50
ATTACHMENT 3	MX1 LOOP INPUTS .....	51
ATTACHMENT 4	MX1 PHONE LINE CONNECTIONS .....	57
ATTACHMENT 5	PSEUDO POINTS .....	61
ATTACHMENT 6	THE VOIP NETWORK (PROPOSED).....	64
ATTACHMENT 7	OCCUPANT WARNING MASS NOTIFICATION Networking .....	65
ATTACHMENT 8	FIRE DETECTION SYSTEM MATRIX.....	66
ATTACHMENT 9	SMALL FIBRE ENCLOSURES .....	71
ATTACHMENT 10	FIBRE ENCLOSURES AND RACKS.....	75

ATTACHMENT 11	FIRE RATED FIBRE CABLE.....	78
ATTACHMENT 12	FIRE RATED FIBRE COLOUR CODE.....	80
ATTACHMENT 13	BARIX PRODUCT DATA SHEET.....	81

## 1 PURPOSE

The IFS Project Briefing Document – Fire Services Guiding Principles sets out the University of Newcastle's minimum requirements for the design, construction, and maintenance of essential fire safety measures. It ensures new and refurbished systems are energy efficient, fit-for-purpose, made from durable good-quality materials, contain no or minimal environmentally harmful substances, and are cost efficient to operate and maintain.

Applicable requirements documented in Workplace Health and Safety legislation, Disability Discrimination legislation, State Environmental Planning legislation, Commonwealth and State legislation, National Construction Codes (NCC), the Building Code of Australia (BCA) and Australian and New Zealand Standards (AS/NZS) are the minimum and mandatory compliance requirements.

Where any ambiguity exists between this standard and the mandatory requirements then:

- a. the highest performance requirements must apply
- b. applicable requirements must follow this order of precedence:
  - i. Workplace Health and Safety legislation
  - ii. Disability Discrimination legislation
  - iii. State Environmental Planning and Assessment legislation
  - iv. All other Commonwealth and State legislation
  - v. NCC, BCA and PCA
  - vi. AS/NZS
  - vii. This standard and other University of Newcastle standards

Applicable standards listed in Section 13: References

## 2 SCOPE

These standards describe the minimum requirements for the design, construction, and maintenance of all essential fire safety measures throughout all buildings owned, operated, and managed by the University of Newcastle.

The standards apply to all planners, project managers, consultants, contractors, sub-contractors, tenants, managing agents and University staff involved in the design, construction and maintenance of existing, new, and proposed University buildings and facilities.

All essential fire safety system products and services provided or specified by designers, consultants, staff, and contractors must conform to this standard.

Where specific applications are not explicitly covered or ambiguity exists, the intent of the design standard must be satisfied. In such cases a return design brief must be provided for review and approval by the issuer of this standard or their appointed delegate who must have relevant technical competence in the subject matter. Additional more stringent requirements to those listed in this standard may apply on a project-specific basis dependent upon risk management and insurance requirements.

The Standard provides:

- a. a reference document to enable consistency with the design and engineering objectives
- b. details of the minimum performance requirements for Planning, Architectural Design, and maintenance.
- c. support of the Strategic Asset Management Plan for the built environment and best practice.

The Standard addresses key objectives:

- a. Quality design which responds, enhances, and complements the environment
- b. Appreciation of the heritage context and cultural history of the campuses
- c. Value for money in all aspects of the project
- d. The design of low maintenance buildings and environments
- e. Longevity of construction approach to design
- f. Standardization of key flashing and ancillary details
- g. Flexible design, to future proof building usage for expansion or adaption to new uses

## 2.1 NEW BUILDINGS

As a minimum, the essential fire safety measures provided in University Buildings must be designed and installed in accordance with the minimum legislative requirements incorporating all Statutory Regulations, Australian Standards, Local Council, Fire & Rescue NSW, Work Health & Safety (WHS) and SafeWork NSW requirements.

Each building must be equipped with the appropriate fire suppression, detection, emergency warning and egress provisions, all designed and installed in accordance with the requirements of the *'Deemed-to-Satisfy Provisions'* of the NCC. Additional measures may also be required to meet specific building hazards and/or the requirements of University Insurers.

Where it is proposed that the *'Performance Requirements'* of the NCC will be adopted to develop an *'Alternative Solution'* in lieu of complying with the *'Deemed-to-Satisfy (DtS) Provisions'*, the consultant/contractor must seek approval from IFS for all proposed *'Alternative Solutions'* during the initial design development. The consultant/contractor must take a long-term balanced view of capital costs, energy costs, maintenance costs and longevity when proposing any *'Alternative Solution'*, comparing the capital and operational costs of each proposed solution with the applicable DtS provisions.

Generally, *'Alternative Solutions'* will only adopt fixed active and passive measures to achieve the *'Performance Requirements'* of the NCC. Where management procedures are proposed to be included as part of an *'Alternative Solution'*, approval must be sought from IFS.

Where *'Alternative Solutions'* are proposed, an Accredited Certifier - Fire Safety Engineer, Certified Fire Safety Practitioner registered with the NSW Building Professionals Board, or Fire Protection Association, or approved equivalent, must be engaged to certify the proposed solution.

The consultant/contractor will consult with IFS, University Risk Management, University WHS Group and Project User Groups, to discuss any additional essential fire safety measures that must be included in the design, in order to suit the proposed occupancy, associated hazards, and the overall fire exposure risk. Additional measures will be determined via a risk hazard assessment process, incorporating details and issues relating to the fire safety within the building, including business continuity, consequence of loss and likelihood of loss.

## 2.2 EXISTING BUILDINGS

The requirements for the refurbishment of existing essential fire safety measures within existing buildings will often be the same as for new buildings. However, there are few existing buildings in the University that have been constructed under current regulations, due to the ever-changing nature of Building Regulations and Australian Standards.



Whilst every endeavour is made to comply with regulations during refurbishments and upgrades, it is unlikely that the full extent of the building regulations can always be met. Therefore, in many cases involving existing building refurbishment, *'Alternative Solutions'* and essential fire safety measures upgrade strategies must be developed in lieu of complying with the *'Deemed-to-Satisfy (DtS) Provisions'* of the NCC. Where *'Alternative Solutions'* are proposed to be adopted in existing buildings, the requirements listed above, must also apply. It is also noted that many University buildings have existing *'Alternative Solutions'*. Where refurbishment occurs within these buildings, the refurbishment works must be performed in accordance with the existing *'Alternative Solution'* or it must be reviewed, updated and re-certified to suit both the refurbishment works and the remainder of the building.

Within any building proposed for refurbishment, the Standard of Performance for all existing essential fire safety measures must be reviewed by the consultant/contractor for compliance with the current NCC and Australian Standard requirements. The details of this review together with a proposed essential fire safety measures upgrade strategy must be submitted to IFS for approval during the initial design development. As the University often chooses to perform voluntary upgrades of essential fire safety measures as part of building refurbishment projects, these details will assist in the determination of the extent of modification and upgrade to existing essential fire safety measures, required to be incorporated into the refurbishment works.

### **3 GLOSSARY OF TERMS**

AS	Australian Standard
ASE	Alarm Signalling Equipment
BCA	Building Code of Australia
BGM	Background Music
BMS	Building Management System
CO	Carbon Monoxide
DLP	Defects Liability Period
EWIS	Emergency Warning Intercommunication System
FIP	Fire Indicator Panel
FMS	Fire Management System
FRL	Fire Resistance Level
HDPE	High-Density Polyethylene
IFS	Infrastructure & Facility Services
ISO	International Organisation for Standardisation
MCP	Manual Call Points
MDF	Main Distribution Frame
MECP	Master Emergency Control Panel
MNS	Mass Notification System
NCC	National Construction Code
O&M	Operations & Maintenance
OWS	Occupant Warning System
PA	Public Address
PABX	Private Automated Branch Exchange
PCA	Plumbing Code of Australia
SSISEP	Sound System and Intercom System for Emergency Purposes
UoN	University of Newcastle

UPS Uninterruptible Power Supply  
VESDA Very Early Smoke Detection Apparatus  
WIP Warden Intercommunication Phones  
WHS Work Health & Safety

## 4 AUTHORITIES AND RESPONSIBILITIES

This standard is issued by IFS. It is approved and by the Operations Manager, IFS. The IFS Operations team are responsible for maintaining the standards and keeping it up to date. The Standard must be reviewed biennially.

## 5 TECHNICAL REQUIREMENTS

### 5.1 GENERAL

Most University buildings are classified as Class 9b buildings, i.e., '*an assembly building, including a trade workshop, laboratory, or the like in a primary school or secondary school*', as defined by the National Construction Code (NCC). This Class 9b classification generally applies to all teaching spaces, computer rooms, teaching laboratories, workshops, and the like, but does not apply to other specialised areas of buildings such as student accommodation (and other premises containing areas for sleeping occupants), carparks, office areas, research laboratories and the like.

The proposed essential fire safety measures to be installed within a building are determined by the NCC building classification, combined with type of construction and rise in storeys. These details, together with any special "entertainment" requirements, must be determined by the consultant/contractor during initial design development and submitted for approval by IFS.

Many University buildings contain health and fire hazards far in excess of those normally found in typical Class 9b assembly buildings. Additionally, the University's duty of care and commitment to Work Health & Safety often requires a higher degree of life safety provision than that provided by the local building regulations and NCC. The NCC requirements for essential fire safety measures in Class 9b buildings may also be considered insufficient for the hazards contained in many University buildings.

The provision of automatic smoke detection, emergency warning systems and safe egress must be incorporated in all new construction projects and in the refurbishment of all existing buildings and services.

The University's minimum requirements for essential fire safety measures are stated below. These requirements may be in addition to, but not in substitution of, legislative requirements.

#### 5.1.1 Design Approach

The University expects consultants and designers to provide designs that meet the project briefs. The following are priorities that consultants and designers are required to be aware of and consider in their designs:

- a. Take a long-term balanced view of capital costs, energy costs, maintenance costs and longevity
- b. As educational and research both progress at rapid rates, usage of buildings and areas within buildings can change several times within the life of a building, systems must be designed to be adaptable for such changes
- c. Ensure that plant and equipment is designed with access and visual impact in mind

### 5.1.2 Engineering Process

The University expects consultants and designers to be fully qualified, experienced, and capable of carrying out all engineering design, equipment selection and construction/installation quality checks.

In selecting equipment, the University expects consultants and designers to select products and system configurations of proven and reliable quality and are compatible with existing systems.

In the designing of all systems, the University expects consultants and designers to follow good industry practice. Further information can be found in the IFS document Engineering Services Briefing Document.

### 5.1.3 Equipment Selection & Sizing

In selecting equipment, the University expects consultants and designers to select products of proven and reliable quality, with reputable support and after sales service.

The provision of spare capacities for future must be considered for all projects. In making such considerations careful analysis of spare capacity against the application of diversity and balance must be considered.

For critical equipment, the University of Newcastle has developed a pre-approved equipment list for the following:

Equipment Type	Pre-approved Model	Part Number
Fire Indicator Panel	Vigilant MX-1	FP0948
PIB	TSP-PIB	FP0986
Moxa	TSP-Moxa	SU0320
Photo Optical Detectors (Smoke)	Minerva 850P	516.850.052.E
Photo Heat Detectors	Minerva 850PH	516.850.051.E
Carbon Monoxide Detectors	Minerva 850PC	516.850.054
Heat Detectors	Minerva 850H	516.850.053.E
Manual Call Points	MCP820	514.800.611 & SU0632
EWIS	QE90	QS1000
Audio Decoder	Barix ExStreamer 100 IP Audio Decoder	
4 Pole Switched FIP Relay	Vigilant ALIM9706/4	PA0646
Small Fibre Enclosure	AFL	FWE-MOD-SM
Large Fibre Enclosure	AFL	FEW-MOD-12-M-C
Fire Rated Fibre	MSS Fibre Systems	CAB-MT-06_SMFR

Any change of equipment must be approved in writing from IFS. It must not be assumed that a change of equipment will be approved.

## 5.2 DESIGN AND CONSTRUCT CONTRACTS

### 5.2.1 General

This section outlines the extent of the services to be provided by the contractor under a Design and Construct contract.

The contractor shall be fully responsible for the complete design of the essential fire safety measures installations, including the selection, sizes and quantity of equipment, and shall provide calculations and drawings and other documentation as necessary to demonstrate conformance with the design parameters, industry practice, IFS requirements, codes, regulations and standards. This includes all calculations required to confirm that existing infrastructure is enough to supply the proposed systems and equipment installed under the project.

The contractor shall allow to fully co-ordinate the documentation with the Architect, Structural Engineer, and all other services consultants / contractors. Please refer to Attachment 1 - DESIGN AND CONSTRUCT CHECKLIST FOR CONSULTANTS.

### 5.2.2 Calculations

As part of the contractor's design, it is expected that the following design calculations as a minimum are produced for review by IFS for approval prior to finalising design:

- a. Equipment selections based on the overall capacities calculated
- b. Water supply calculations inclusive of pumps, town main and tank supplies
- c. Pipe sizing calculations
- d. Electrical and cable sizing calculations

All other calculations necessary to illustrate equipment reticulation and components have been selected fully in accordance with the project requirements and this specification

### 5.2.3 Drawings and Documentation

The contractor shall provide design, construction, and as-built drawings, which may be either design drawings produced by the contractor or shop drawings produced by equipment manufacturers.

The contractor is responsible for producing all design and as-built documentation, including, but not limited to:

- a. Concept Design documentation (as required)
- b. Detailed Design documentation, including:
  - i. Layout Drawings
  - ii. Details
  - iii. Schematics
  - iv. Design certification
  - v. Equipment details
  - vi. Testing / commissioning procedures
- c. Workshop drawings, including drawings for the purpose of system manufacture
- d. As built drawings, including detailed drawings demonstrating the as installed system
- e. Operations and Maintenance manuals
- f. Training manuals

All design documentation shall be approved by IFS prior to any works progressing onsite.

Workshop, As-Built drawings, and O&M manuals shall be submitted for review prior to final sign off.

### 5.2.4 Technical Submittals

Technical submittals shall be provided with the full technical and spatial requirements of each proposed plant item. The technical submissions shall include, where applicable, but not be limited to:

- a. Certified shop drawings of each item complete with sectional weights and point loads.
- b. Certified noise levels from each plant item.
- c. Electrical requirements including starting current, running current, operational voltage, power consumption, recommended protection devices, wiring diagrams, connection, and terminals details. Also detail of how cables are terminated to the plant item and earthing requirements shall be provided.
- d. Pump Curves as applicable.
- e. Recommended spares schedules and projected future availability (to ensure that redundant components are not used)
- f. Requirements for specialist tools to maintain the plant item.
- g. Maintenance zones and requirements including weights of any replaceable components.
- h. Manufacturer's recommendations for installation including ventilation and thermal requirements.
- i. Confirmation of product lifespan assuming maintained to manufacturers recommendations.
- j. Where equipment model numbers / references are stated, these are indicative only and the Contractor MUST ensure the selected plant fully complies with the standard

## 5.3 FIRE SYSTEM MANAGEMENT (FMS)

An FMS Network is installed at the University to monitor fire system status signals for all Automatic Fire Detection & Alarm Systems, Automatic Fire Sprinkler Systems and Fire Pumps installed across all University

facilities. For the Callaghan and Ourimbah Campuses, the FMS also provides automatic fire brigade alarm facilities via Alarm Signalling Equipment (ASE) installed at the fire brigade FIP located at the West Campus Pump House on Callaghan Campus and outside the entry to the Facilities Management building at Ourimbah.

All New and Upgraded Panels are to be connected to the Fibre Network.

Minimum requirements for these are shown in Attachments 6 thru 12 or approved equivalent.

During the initial design development stage for each project, the consultant/contractor must consult and obtain approval from IFS for the extent of modifications required to the FMS Network. These modifications must incorporate changes to the existing fire systems or installation of new FIP's, sprinkler systems and fire pumps into the project works.

Modification of the site communications network to accommodate new FMS Network signal connections must be included in the scope for all new buildings and refurbishment projects. This includes interface with the university's Buildings Management System (BMS).

New FIP's, fire sprinkler systems, sprinkler control valves and fire pumps, must be connected to the FMS to provide high-level interface signals required to provide control and monitoring of the fire equipment for alarm, fault, and isolate conditions.

Due to the complex nature of the FMS Network (Please refer to Attachments 2 to 5 for Callaghan Fire System Network Topology), an approved University of Newcastle contractor must perform all project-related alteration works associated with the installation and connection of devices connected to the FMS, including any required programming and modification to existing FMS equipment. If modifications are made to the network topology, the documents included as Attachments 2 to 5 must be updated and submitted for approval. Editable copies of these documents can be obtained from IFS as required. These works form part of the overall project scope and must include all modifications to the following equipment:

**Callaghan:**

- a. Main Campus FMS FIP PUMP ROOM – Johnson Controls MX1
- b. FMS Eastern entrance FIP 2 – Johnson Controls MX1
- c. FMS Western entrance FIP 1 – Johnson Controls MX1
- d. FMS Mimic Panel IFS building – Johnson Controls MX1
- e. XL Graphics Interface (including update of drawings)

**Ourimbah:**

Main Campus FMS FIP – Tyco MX4428

**5.3.1 Callaghan, Ourimbah & City Campuses**

All existing FIPs, fire sprinkler systems, sprinkler control valves and fire pumps must be connected to the Callaghan campus FMS FIP via the building PABX/MDF/Comms Room to the ICT Building PABX room, or to the dedicated Fire Rated Fibre Network (fibre network currently installed at Callaghan campus only) including The University's XL graphics system and the site BMS.

**Callaghan:**

The FMS main FIP (West Campus Pump House) contains the Alarm Signalling Equipment (ASE) for this site. In addition, ASE's are located at sites adjacent to the Callaghan Campus as follows:

- Edwards Hall
- NIER Building A

### **City Campus:**

ASE's are located as follows:

- Conservatorium of Music, Auckland Street, Newcastle
- Northumberland House, Auckland Street, Newcastle
- University House, Auckland Street, Newcastle
- NUspace, 409 Hunter Street, Newcastle
- Q Building, 16B Honeysuckle Dr, Newcastle

All building FIPs, fire sprinkler systems, sprinkler control valves and fire pumps installed in City campus buildings must be connected to the Callaghan campus FMS Network via addressable IP network connections. This includes the site BMS.

### **Ourimbah:**

The FMS main FIP contains the Alarm Signalling Equipment (ASE) for this site. All building FIPs, fire sprinkler systems, sprinkler control valves and fire pumps installed in Ourimbah campus buildings must be connected to the Callaghan campus FMS Network via addressable IP network connections.

10 Chittaway Road, Ourimbah, NSW, 2258

### **Tamworth:**

Education Centre, 114/148 Johnston Street, North Tamworth NSW 2340

### **Taree:**

Manning Education Centre, 69A High Street, Taree NSW 2430

### 5.3.2 Other Locations

All building FIPs, fire sprinkler systems, sprinkler control valves and fire pumps installed in remote campus buildings must be connected to the Callaghan campus FMS Network via addressable IP network connections.

ASEs are generally installed at each individual building FIP and/or fire sprinkler system for fire and rescue NSW interface.

### 5.3.3 High Level Interfaces

For buildings without individual ASE's automatic fire brigade callout are currently provided via copper telephone lines to the FMS FIP. The University is currently installing fire rated fibre to provide high level interface between building FIPs to the main FIP. The high-level interface is to be achieved using a vigilant panel link internet protocol bridge and a moxa 405 single mode optical fibre media device to achieve system compatibility.

#### **All New and Upgraded Panels are to be connected to the Fibre Network**

The contractor shall supply and install the necessary hardware to allow High Level Interface for the future FMS Network. In addition, if connection is made the contractor shall check, commission, and demonstrate the operation of the FMS high level interface prior to Practical Completion of the works.

### 5.3.4 Low Level Interfaces

Low level interface connections to the FMS allow monitoring signals only for specified inputs from the building to the main FIP. For buildings without individual ASE's, automatic fire brigade callout signals from buildings with low level interfaces are provided via copper telephone lines to the FMS FIP. Individual copper fire lines must be provided for both dry and wet fire brigade call facilities from each building.

Low level interface signals from building FIP's generally include:

- a. FIP Alarm
- b. FIP Isolate
- c. FIP Zone Isolate
- d. FIP Fault
- e. FIP 240V Power Failure



### 5.3.5 Fire System Connections to Communications Network

Connections between the building FIP's, sprinkler systems, and the FMS are performed via the site communications network using a combination of copper phone lines, single mode optical fibre cabling, and IP network connections.

Connections shall generally consist of:

- a. Dry Fire Brigade Call - fire rated cable to building MDF with copper phone line connection to FMS FIP (for existing systems only)
- b. Wet Fire Brigade Call – fire rated cable to building MDF with copper phone line connection to FMS FIP (for existing systems only)
- c. FMS & MNS High Level Network Interfaces - Provide a fire rated fibre point to point connection between fire panels to the existing ring network (for all new systems)
- d. Callaghan is currently installing a stand-alone fire rated Fibre network for connection. The Topology for this system is a ring Network-2 x 6 core fire rated single mode cables to each panel.

## 5.4 ACCESS PANELS, DOORS & HOPPERS TO FIRE RESISTING SHAFTS

All fire rated access panels, doors and hoppers must be:

- a. Equal to the FRL of the shaft in which they are installed in.
- b. Provided with identification labelling in accordance with the requirements of AS4072.1 Appendix B and AS1851-2005.
- c. Detailed on the building asset register using a Maximo asset classification.
- d. Included in a consolidated Passive Fire and Smoke Containment System report, delivered under the scope of the project works. The report must provide comprehensive details of all items listed under Section 12 of AS1851-2012, including:
  - i. consolidated as-built fire compartmentation drawings for each area and level of the building affected by the project works, documenting the exact location of all existing and new fire walls, floors, and ceilings, together with the location of all existing and new passive fire and smoke containment measures
  - ii. corresponding photos of each individual passive fire and smoke containment measure
  - iii. certification of each individual passive fire and smoke containment measure

## 5.5 AUTOMATIC FAIL-SAFE DEVICES

### 5.5.1 General

Automatic fail-safe devices include magnetic door holders and fire trips to security door interfaces (electric strikes, electric mortise locks, drop bolts, magnetic locks, etc.), which are required to activate when a fire/smoke condition is sensed via the building fire sprinkler or fire detection system. These devices must be normally energized to enable them to return to the fail-safe position when power to the device is lost.

### 5.5.2 Magnetic Door Holders

The consultant team must fully liaise with IFS to determine requirements and locations of fire and/or smoke rated doors required to be normally held open by magnetic door holders. Magnetic door holders must be mounted at the top of fire doors and not at the base. Each magnet must be fitted with a local release button so where more than one door panel is fitted to a single opening, one switch must release all magnetic door holders. Both parts of the magnet must be rigidly secured.

Magnetic door holders must be powered from the FIP and installed on a separate control loop to security door interfaces and air conditioning fire trip cabling, with individual isolation facilities for each loop located at the FIP.

### 5.5.3 Fire Trip to Security Door Interfaces

The consultant team must fully liaise with IFS and Security Services to determine the locations of security door interfaces. For all required egress doors that can be locked by the electronic security system, fire trip interfaces must be installed to automatically unlock the door in the event of any fire alarm system or sprinkler system activation.

Unless the electronic security system controller, cabling and associated equipment are designated as a fail-safe device, fire trip cabling must run from the FIP/sprinkler system pressure switch and connect directly to the door interface. Further technical information and requirements regarding security door interfaces may be found in the IFS document IFS Electronic Security Specification.

Fire trips to security door interfaces must be installed on a separate control loop to magnetic door holders and air conditioning fire trip cabling, with individual isolation facilities for each loop located at the FIP.

All doors provided with a fire trip to a security door interface must also be provided with a green Break Glass Unit labelled 'Door Release' fixed to the wall adjacent to the door handle. This University requirement is to ensure egress through the door is accessible in the event of all types of emergencies.

A4 signage must also be mounted on the door at eye level. The signage must be green with white lettering, indicating:

'EMERGENCY EXIT ONLY

THIS EXIT DOOR AUTOMATICALLY UNLOCKS IN THE EVENT OF A FIRE,  
FOR OTHER EMERGENCIES ACTIVATE ADJACENT BREAK GLASS UNIT'

Include '*DOOR ALARMED*' if applicable.

The details of all fire trips to security interfaces devices will be included on the building's essential fire safety measure asset register, fire system matrix, and the associated drawings.

## 5.6 AUTOMATIC FIRE DETECTION AND ALARM SYSTEMS

### 5.6.1 General

The University of Newcastle (The University) currently has a variety of existing fire detection and alarm systems and FIPs installed throughout its buildings, including traditional conventional and addressable fire systems. To determine the fire detection and alarm system strategy for the building, the consultant/contractor must fully liaise with IFS and the relevant authorities during the initial design development stage for each project.

As a minimum, all buildings with total floor areas greater than 1000m<sup>2</sup> must be provided with a complete fire detection and alarm system connected to the main FIP, FIP 1, and FIP 2 to provide automatic fire brigade call facilities in full compliance with AS1670.1, with additional control and monitoring provided at the Mimic panel located at the services building.

When carrying out refurbishment work in buildings that require an upgrade from conventional detector circuits to addressable systems, rewiring and transfer must include the entire affected circuit and not just the part of the circuit that is relevant to the refurbishment area.

When upgrading or extending part of an existing fire detection system, the current essential services maintenance contractor must inspect the system at Practical Completion to confirm that the system is fully operational and satisfies all relevant requirements. The cost of this inspection will be included as a Project cost.

### 5.6.2 Fire Indicator Panel (FIP)

Fire Indicator Panels must comply with the following details:

- a. New FIPs must be fully addressable type, suitable for high level interface connection to the University fibre FMS Network (Johnson Controls MX vigilant MX-1 FIP). The type of panel proposed to be installed will be subject to approval by IFS. Networking will consist of a PIB and Moxa arrangement thru single mode Fibre.
- b. FIP cabinets and associated hardware - loop cards, relay cards, input/output (I/O) cards, network cards, I/O controllers, etc. - must be sized to adequately serve the entire building or area which they serve, with a minimum of 20% spare capacity on all equipment and cabling.
- c. New FIPs installed in existing buildings must be provided with enough zone display cards to accommodate the transfer of all existing detectors and circuits serving the entire building.
- d. FIPs must be located at the most accessible building entrance designated for Fire & Rescue NSW (i.e. the entrance accessible to a fire appliance).
- e. The FIP must be placed in a position that allows for both audible and visual fault monitoring by the building occupants. Under no circumstances are FIPs to be in storerooms or offices or other 'out of the way' places.
- f. Separate isolating facilities for each group of detectors and all equipment interfaces must be provided at the FIP for EWIS/OWS, magnetic door holders, security interface devices, air conditioning trips, sprinkler system interfaces and main fire bell/strobe.
- g. Generally, red manual call points (MCP) connected directly to the FIP will not be accepted, apart from the one red MCP required to be provided at the FIP.
- h. Individual LED indicator lamps must be provided for each of the following signals generated from interfaced equipment connected to the FIP:
  - i. Detector zone alarm
  - ii. Fire sprinkler alarm
  - iii. Fire pump (sprinkler and hydrant) status indication; run, fault, low fuel level (for diesel types)
  - iv. Fire sprinkler flow switch alarms (one indicator per flow switch)
  - v. Fire sprinkler and hydrant system valve monitor switches (one indicator per location); open, closed
  - vi. Fire sprinkler pre-action systems; low air pressure alarm
  - vii. VESDA status indication; airflow fault, alert alarm, action alarm, fire 1 alarm, fire 2 alarm
- i. Where existing FIPs require modification of existing programs and/or software to incorporate changes as a result of refurbishment works, these modification works must be carried out by an approved University fire services contractor. The cost of these works must be fully included in the tender sum for the Project.
- j. All installed addressable devices must be programmed to appear on the FIP LCD display, indicating the type of device, point address, and zone location. The naming convention for programming the location of the device must indicate the level, room, and room name, eg, 'L2, Room 201, Men's Toilet'.
- k. To eliminate the possibility of false alarms, FIP's must be capable of providing alarm verification facilities. Approval from IFS must be sought prior to incorporating alarm verification in any area.

- l. Building sub-FIPs must not be installed.
- m. A3 size framed and covered block plan(s) must be installed adjacent to the FIP. This must show the extent of alarm zones and all addressable devices and loop numbering for each item of equipment and each level of the building controlled by the FIP.
- n. Where existing fire detection and alarm systems are refurbished, any existing block plans must be altered to suit the works performed as part of the refurbishment. A system interface diagram/matrix must also be included as part of the block plan information, in accordance with the requirements of AS1851. The interface diagram/matrix must be supplied to IFS to enable vetting and uploading to the asset database.
- o. Adequate space for the storage of AS1851 test logbooks must be provided within the FIP cabinet or alternatively a separate logbook cabinet must be provided.

### 5.6.3 Detectors

Fire detectors must comply with the following details:

- a. All new fire detection and alarm systems must be equipped with fully addressable detectors (MX type), complete with adjustable sensitivity. New detectors proposed to be connected to existing systems must be fully compatible with the existing FIP equipment listing requirements.
- b. Detectors must be suitably selected for each location in accordance with AS1670 Appendix A - Guidance for the Selection of Detectors. Where smoke detectors are indicated as the suggested detection device, photoelectric smoke detectors must be installed.
- c. Where detectors are prone to false alarms, multi-criteria detectors with adjustable sensitivity must be installed.
- d. Detector dust caps must be provided for all new detectors installed as part of a project.
- e. For smoke detectors installed in new student accommodation and other sleeping areas, the provision of addressable multi-criteria detectors with addressable sounder bases is preferred. The photo-electric smoke component of the detector is programmed to activate all sounder bases within a residence and auto resets once the smoke is cleared. The thermal component of the detector is programmed to activate fire brigade call facilities and EWIS operation throughout the building, in conjunction with all other fire mode functions. Note that this arrangement may require an alternative Fire Engineered Report to achieve compliance with regulations.
- f. Where detectors installed as part of a project have been incorrectly selected or located and are found to have caused multiple alarm activations during the DLP, the contractor must replace and rectify the detectors at their expense.
- g. All detectors installed within a building must have indicating bases or heads providing the same indication throughout for both polling and alarm conditions.
- h. Where detectors are in concealed spaces (such as ceiling spaces, cupboards, sole occupancy units, air handling systems and the like), remote indicators must be provided. Remote indicators must be provided for both conventional and fully addressable type detectors.
- i. All detectors must be fully accessible for maintenance. Accessibility to concealed spaces will be achieved via ceiling access panels or accessible walkways. Where accessibility to detectors is difficult, the use of Famco bracketing or VESDA must be considered.
- j. Photoelectric smoke detectors must be provided in all electrical distribution board cupboards, telecommunications cupboards, electrical switch rooms and lift motor rooms
- k. For paths of travel to exits, photoelectric smoke detectors must be installed. Where it is deemed inappropriate to install these detectors due to the possibility of unwanted alarms, multi-sensor CO and heat detectors must be considered.

- l. Probe type thermal detectors connected to both the building FIP and the fume cupboard controller must be provided within all fume cupboard exhaust flues. Remote indicators must be provided in these cases.
- m. Beam type detectors may be selected for large open areas, provided adequate access is provided to maintain the detector.
- n. Care must be taken to ensure that heaters, air conditioning registers, ceiling fans and light fittings are not located within the minimum required distance from smoke and thermal detectors.
- o. Detectors prone to moisture shall be waterproofed to prevent false alarms.
- p. All addressable devices must be clearly labelled with the addressable device number as listed on the panel. For detectors, labelling can be mounted on the detector head, the base, or the remote indicator. Labels must be permanent with an adequate text size clearly visible from the floor level immediately under the device.
- q. Detectors within construction areas must be adequately protected from contamination during the construction works. This may be achieved by the provision of dust caps on all detectors or the removal of the detector heads from the construction site and stored in a dust free environment.
- r. Aspirated smoke detection system must be VESDA, or IFS approved equivalent.
- s. The use of VESDA must be considered for use in areas of high sensitivity, high value, and high risk. Additionally, VESDA must be installed in areas where accessibility to detectors is difficult. Areas proposed for the installation of VESDA must be submitted to IFS for approval. Examples of these types of areas are:
  - i. Clean rooms
  - ii. Electron Microscope rooms
  - iii. Laboratories containing high value equipment, e.g., MRIs, TEMs, Mass Spectrometers
  - iv. Essential computer network and communication facilities
  - v. Museums containing valuable assets
  - vi. Heritage areas
  - vii. Archive areas
  - viii. Atrium areas
  - ix. Animal houses
  - x. Flammable Liquid stores
- t. VESDA systems must operate independently of other detection/suppression systems, however they must be connected to the building FIP to provide indication of all alarm levels in order to allow early response by Security Patrol.
- u. The manufacturer of VESDA (Xtralis) must be consulted regarding the optimum design for the installation. Only VESDA accredited installers are permitted to install a VESDA system.
- v. All VESDA installations must be provided with remote display modules located at the VESDA controller or FIP , to provide visual representation of smoke levels and alarm and fault conditions.

#### 5.6.4 Occupant Warning Systems (OWS)

Occupant warning systems must comply with the following details:

- a. Where buildings are not provided with EWIS/SSISEP, an OWS must form part of the fire detection and alarm system.
- b. New OWS must consist of an amplified sound system producing the evacuation signal in accordance with the requirements of ISO 8201. Typical system installed is to include a vigilant T-gen 2 grade 3 EWS system.

- c. OWS must be installed with the necessary network and hardware for the future campus Mass Notification Network. This includes a RJ45 socket and a CAT6A cable connecting the FIP to the nearest network room.
- d. OWS Mass Notification Requirements- Configuration of each Barix unit. Each FIP to link the system network, Data Room FIP Network Connections, Data Room XLG Configuration x 2. Local FIP Network Configuring.
- e. See drawing Attachment 9 Typical Mass Notification System Design
- f. Existing sounder or bell type OWS must be upgraded to amplified sound system type OWS during building refurbishment projects in order to achieve the evacuation signal tone and sound pressure level requirements of AS1670.1. New sounder or bell type OWS must not be installed.
- g. All new OWS equipment installed in existing buildings must be adequately sized to provide sufficient sound levels to accommodate speaker installation throughout the entire building. An additional 30% spare capacity on amplifier capacity must also be provided to accommodate future additional speakers.
- h. New OWS must be 19-inch rack mounted and provided with a microphone and appropriate key switching at the FIP to allow PA functions.
- i. Sound pressure levels must be provided in accordance with the requirements of AS1670.1.
- j. Occupant warning speakers must be provided in accordance with the requirements for EWIS/SSISEP.
- k. Commissioning details indicating measured sound pressure levels must be provided on the as-built drawings and within the O&M manual for all new and refurbishment works.

#### 5.6.5 Cabling

Fire detection and occupant warning system cabling must comply with the following details:

- a. AS1670.1 2018 - 3.24.3 Cable marking. For ELV transmission paths not installed within cable conduit, the outer sheath of a cable shall be coloured red with contrasting marking "ELV Fire" at intervals not exceeding 2 m.
- b. For LV telecommunication transmission paths not installed within conduits, the outer sheath of the cable shall be red with a white stripe with contrasting marking "LV Fire" at intervals not exceeding 2 m.
- c. Specialist cables, including optical fibre and multicore, that are not available with the marking in this clause shall have permanent red markers of at least 25 mm in width spaced at intervals of not more than 2 m along the cable length when not installed in conduit, and clearly marked ELV Fire or LV Fire at the point of termination.
- d. For ELV transmission paths not installed within cable conduit, the outer sheath of a cable shall be coloured red with contrasting marking "ELV Fire" at intervals not exceeding 2 m.
- e. For LV telecommunication transmission paths not installed within conduits, the outer sheath of the cable shall be red with a white stripe with contrasting marking "LV Fire" at intervals not exceeding 2 m.
- f. Specialist cables, including optical fibre and multicore, that are not available with the marking in this clause shall have permanent red markers of at least 25 mm in width spaced at intervals of not more than 2 m along the cable length when not installed in conduit, and clearly marked ELV Fire or LV Fire at the point of termination.
- g. AS1670.14 2018 3.6.3 Cable marking

- h. For ELV transmission paths not installed within cable conduit, the outer sheath of a cable shall be coloured red with contrasting marking "ELV Fire" at intervals not exceeding 2 m.
- i. For LV telecommunication transmission paths not installed within conduits, the outer sheath of the cable shall be red with a white stripe with contrasting marking "LV Fire" at intervals not exceeding 2 m.
- j. Specialist cables, including optical fibre and multicore, that are not available with the marking required by this clause shall have permanent red markers of at least 25 mm in width spaced at intervals of not more than 2 m along the cable length when not installed in conduit, clearly marked at the point of termination.
- k. All cabling must be fixed to structural elements of the building. Adhesive type fixings are not accepted.
- l. Cabling must be fixed independently of all other services and building elements such as suspended ceiling supports. Cabling must not be installed laying on ceilings.
- m. Cabling must be adequately segregated from other electrical and data cabling. This includes segregation of the fire detection cabling from the EWIS/SSISEP cabling for the future campus vigilant voice over internal protocol (VOIP) interface to connect to the mass notification network.
- n. Cabling must generally be installed concealed in most locations. Where concealed cabling cannot be achieved, cabling must be installed in surface mounted conduit painted to match the adjacent surfaces. The location of all exposed conduits runs must be approved by IFS prior to installation.
- o. Non-fire rated cabling installed that activate fire trip functions must be fail safe (i.e., loss of power or a cut cable will activate the fire trip function).
- p. For further details of cabling refer to the Electrical Standards.

## 5.7 AUTOMATIC FIRE SPRINKLER SYSTEMS

### 5.7.1 General

Consideration must be given by the Consultant/Contractor for the use of sprinklers in all University buildings. This consideration must examine the overall benefits provided by sprinkler systems, such as life safety, property protection and business continuity, to minimise the risk of the loss to University facilities and operations caused by extensive fire damage.

Where water damage caused by accidental operation or leaks from the sprinkler systems may cause extensive damage to property and equipment installed in dedicated rooms of the building, the installation of a dry pipe pre-action sprinkler system will need to be considered.

All automatic sprinkler systems must be connected to the building FIP, with the following signals provided:

- a. sprinkler alarm
- b. sprinkler isolated
- c. sprinkler pump running
- d. sprinkler pump fault
- e. sprinkler pump low fuel level
- f. sprinkler stop valve closed
- g. sprinkler flow switch

The system must be designed to allow omission of weekly testing of the sprinkler system and associated sprinkler pumps, in accordance with the requirements of AS1851. Additionally, all on-site documentation and equipment required by AS2118.1 and AS1851 must be revised and/or provided to suit all system

refurbishments and new works. This includes, but is not limited to, the provision of block plans, fire system interface diagram/matrix, pressure gauge schedules, water supply information, spare sprinklers, and spanners.

The sprinkler control valves must be located in a position that is accessible to Fire and Rescue NSW response appliances. Clear directions to the sprinkler control valve location must be posted adjacent to the FIP. A location plate indicating the position of the sprinkler control valves must be installed on the outside of an external wall.

### 5.7.2 Water Supplies

Automatic fire sprinkler system water supplies must comply with the following details:

- a. When designing and installing new fire sprinkler systems, or upgrading existing systems, the consultant/contractor must confirm whether the existing water supply pressure/flow details satisfy the requirements of the system.
- b. The fire sprinkler system must be supplied by the potable water supply from either the University reticulation system, direct from the Local Authority water main or from the dedicated boosted fire water system. Assessments for the requirement of augmentation to the water supply must be made prior to installation.
- c. The building hydrant demand must be available in addition to the building sprinkler demand to ensure that both systems can operate simultaneously from the water supply provided to the building.
- d. All fire services test water must recycle back into the fire system storage tanks or alternatively to water retention tanks, to enable reuse of the test water.
- e. Test drains and sumps must be provided to enable water flow testing.
- f. Fire water supply tanks must be either of concrete construction or stainless-steel panel type, complete with access ladders and lockable manhole covers to allow internal tank inspection and cleaning. Tanks must be complete with internal dividing walls and associated supply and drain connections to allow a minimum of 50% of the required storage capacity to be available during tank cleaning and maintenance operations. Visual tank water level indicators and high- and low-level alarms connected back to the FIP must be installed. Panel tanks must be installed on raised supporting beams allowing access to visually inspect the underside of the base of the tank. A minimum clear distance of 500mm around the walls, base and roof of the panel tank must be provided to allowance maintenance and inspection. Tanks with internal bladders will not be accepted.

### 5.7.3 Hazard Classifications

Automatic fire sprinkler system hazard classification must comply with the following details:

- a. For all new sprinkler system installations and refurbishments, the minimum level of protection for University buildings must be specified as Ordinary Hazard Group 1, as defined in AS2118.1. Light hazard sprinkler systems will not be accepted in University buildings.
- b. Generally, hazard classifications must be specified in accordance with AS2118.1, except for the above listed minimum requirement and the following specific areas within University buildings, where the minimum hazard classifications must be:
  - i. Ordinary Hazard Group 1 - offices, lecture rooms, lecture theatres, student accommodation
  - ii. Ordinary Hazard Group 3 - libraries, laboratories, museums

### 5.7.4 Pipework and Equipment

Automatic fire sprinkler pipework and equipment must comply with the following details:

- a. Underground pipework and pipework installed external to the building must suit the



requirements listed in the IFS Hydraulic Services Standard, IFS Trenching and Excavation Standard and the IFS Excavation Permit.

- b. Internal pipework must be reticulated neatly throughout the building. Pipework must be run parallel and plumb with adjacent pipework and other building services and elements.
- c. Pipework must be securely and independently fixed to structural elements of the building and must allow for movement in both the structure and the adjacent equipment.
- d. Pipework must be concealed where possible. Where pipework is installed exposed, it must be painted with one primer coat and two finishing coats of an approved colour to suit Architectural requirements. See IFS document THE UNIVERSITY Interior Design Guidelines for further information.
- e. Stainless steel braided flexible pipe droppers are preferred over fixed pipework for final connections to sprinkler heads fixed in suspended ceilings. Flexible pipe droppers must be adequately supported to the ceiling using an approved fixing system.
- f. Pipework must generally be medium steel pipe or galvanized pipe to suit AS1074 OneSteel Fireplus Medium or approved equivalent.
- g. Joints and fittings on pipework of 50mm diameter or less must be screw fixed. Joints and fittings on pipework of 65mm diameter or greater must be roll grooved or flanged.
- h. All fire sprinkler pumps, and pump controllers must be equal to those manufactured and supplied by Prime Pumps or KSB Ajax Pumps, or approved equivalent.
- i. Pumps shall be housed in a pump room with access in accordance with the NSW fire brigade requirements and AS/NZS 2118.1-6 and AS/NZS 2941.
- j. Sprinkler heads installed in false ceilings must be provided with a two piece semi recessed escutcheon plate.
- k. Sprinkler heads installed in communications rooms must be installed in the upright position and provided with robust sprinkler guards/cages.
- l. Sprinkler systems must be provided with a brigade booster connection designed and installed to suit AS2419.1.
- m. Sprinkler systems must be provided with backflow prevention devices as per the requirements listed in the IFS Hydraulic Standards.

## **5.8 EMERGENCY LIFTS**

Emergency lifts must be installed to suit the requirements of the NCC. Technical information and requirements regarding emergency lifts may be found in the IFS document Guidelines for the Design of Vertical Transportation Services.

## **5.9 EMERGENCY LIGHTING**

Emergency lighting must be installed to suit the requirements of the NCC. Technical information and requirements regarding emergency lighting are included in the IFS document UON-ESS-104 Emergency Lighting and Illum Exit Signs.

## **5.10 EMERGENCY WARNING AND INTERCOMMUNICATION SYSTEM (EWIS)**

### **5.10.1 General**

EWIS, or Sound Systems and Intercom Systems for Emergency Purposes (SSISEP), must be designed and installed in all University buildings having a rise in storeys of 3 or more, and in University assembly buildings that contain lecture theatres, seminar rooms, libraries, museums, student computer facilities, teaching laboratories/workshops, and the like, with a total building floor area greater than 1000m<sup>2</sup>.

In University buildings where the above clause does not require EWIS to be designed and installed, an Occupant Warning System (T-Gen 2) is required to be designed and installed, as indicated in the Automatic Fire Detection and Alarm System section of this document.

A vigilant voice over internet protocol (VOIP) interface is to be provided for connection to the University mass notification system with all EWIS'.

EWIS must respond immediately to activation of the FIP, fire sprinkler installation, or a manual call point. To supplement the audible warning system, visual warning devices must be provided at strategic locations (generally in corridors and/or public spaces) on all levels, and in areas with high ambient noise levels.

In sound sensitive areas such as animal houses, consideration must be given to the provision of visual warning devices only in lieu of installing the audible warning system. However, advice is to be sought from IFS and the animal house staff before the proposed alarm type is selected.

EWIS must be installed with the necessary network and hardware for the campus Mass Notification Network. This includes a RJ45 socket and a CAT6A cable connecting the EWIS to the nearest network room or connection to the Fire Rated Fibre Network. Please refer to Attachment 3 - THE VOIP NETWORK (PROPOSED).

#### 5.10.2 Master Emergency Control Panel (MECP)

Master emergency control panels must comply with the following details:

- a. The MECP must be housed in the same cabinet as the FIP. In existing buildings where this may not be possible due to available space, the MECP will generally be located in an accessible location adjacent to the building FIP.
- b. The MECP fascia layout and operational characteristics must be equal or equivalent to the Vigilant QE90 type EWIS panel. The type of panel proposed to be installed will be subject to approval by IFS.
- c. Where the MECP is proposed to be designed and installed flush into wall spaces, ventilation space for heat dissipation from the EWIS cabinet must be included, as EWIS amplifiers generate considerable heat.
- d. MECPs must be installed with separate evacuation zones provided for each level and a minimum spare capacity for an additional two (2) evacuation zones.
- e. MECPs must be installed with the necessary network and hardware for the future campus Mass Notification Network.
- f. Each evacuation zone will be provided with a dedicated amplifier. All amplifiers must be provided with 30% spare capacity to allow for additional future speakers to be installed within each zone.
- g. An A3 block plan must be installed adjacent to the MECP, showing each level of the building and the evacuation zones and position of all WIPs installed.
- h. All MECP's must be provided with VOIP equipment and a network card to allow connection of the panel to the future campus wide evacuation system.
- i. To eliminate the potential for constant hiss from the EWIS/OWS speakers caused by the background music (BGM) input function being permanently activated, the MNS input to each EWIS and OWS panel must be programmed to activate the BGM function of the panel, only when the MNS is being manually operated.
- j. An output from the MECP to the FIP must be provided to allow fire trips to AV and security door screamers to be activated when the MECP is in alert, alarm, or PA mode.

#### 5.10.3 Emergency Warning System Operation

Unless otherwise directed, all EWIS will be arranged for the following automatic sequence of operations:

- a. No delay from receipt of fire system activation to operation of ALERT signal throughout entire building.
- b. ALERT signal must sound for 60 seconds throughout the entire building then automatically change to EVAC signal throughout the entire building.

- c. No cascading, i.e. signals must be provided throughout all areas of the building simultaneously.
- d. Standard voice recorded messages must be provided with the EVAC signal.
- e. ALERT and EVAC signal types must meet the requirements of AS1670.4.

Commissioning details indicating measured sound pressure levels and speech intelligibility must be provided for all areas and rooms within the building. These details will be provided on the as-built drawings and within the O&M manual, for all new and refurbishment works.

Individual inputs from the FIP and/or sprinkler system flow switches must be provided to the MECP for each evacuation zone in order to enable the building fire warden team to easily identify, via LED operation on the MECP, the evacuation zone in alarm. Similarly, activation of any MCPs must also provide indication of the specific evacuation zone activated.

#### 5.10.4 Emergency Call Points (ECP) and Warden Intercommunication Phones (WIP)

ECPs and WIPs must comply with the following details:

- a. Provided within each evacuation zone.
- b. Where fire hose reel cupboards are located in the vicinity of fire egress stairs, WIPs will be installed in visible positions immediately adjacent to each fire hose reel cupboard
- c. Each WIP must be provided with labelling that corresponds to the associated labelling on the MECP and signage.

#### 5.10.5 Cabling

EWIS cabling must comply with the following details:

- a. AS1670.14 2018 3.6.3 Cable marking
- b. For ELV transmission paths not installed within cable conduit, the outer sheath of a cable shall be coloured red with contrasting marking "ELV Fire" at intervals not exceeding 2 m.
- c. For LV telecommunication transmission paths not installed within conduits, the outer sheath of the cable shall be red with a white stripe with contrasting marking "LV Fire" at intervals not exceeding 2 m.
- d. Specialist cables, including optical fibre and multicore, that are not available with the marking required by this clause shall have permanent red markers of at least 25 mm in width spaced at intervals of not more than 2 m along the cable length when not installed in conduit, clearly marked at the point of termination.
- e. All cabling must be fixed to structural elements of the building. Adhesive type fixings are not accepted.
- f. Cabling must be fixed independently of all other services and building elements such as suspended ceiling supports. Cabling must not be installed laying on ceilings.
- g. Cabling must be adequately segregated from other electrical and data cabling. This includes segregation of the fire detection cabling from the EWIS cabling.  

Cabling must generally be installed concealed in most locations. Where concealed cabling cannot be achieved, cabling must be installed in surface mounted conduit painted to match the adjacent surfaces. The location of all exposed conduits runs must be approved by IFS prior to installation.
- h. Fire rated cable and cable supports must be used for all WIPs and the first speaker in each evacuation zone.
- i. For further details of cabling refer to the IFS document UON-ESS-101 General Electrical Specification.

### 5.11 EMERGENCY EVACUATION DIAGRAMS

Emergency evacuation diagrams are installed throughout all levels of all University buildings. The diagrams provide information regarding the basic emergency evacuation requirements for each level of the building. Additionally, the diagrams also provide a means of wayfinding for building occupants, students, and visitors, and are therefore required to include room numbers for all spaces on each level.

For new or existing buildings, new emergency evacuation diagrams must be designed and installed as part of the project scope of works, in accordance with the standard University format, and the requirements of AS3745-2010.

Some existing emergency evacuation diagrams were originally designed and installed to suit the requirements of AS3745-2002. These Australian Standards have subsequently been superseded by AS3745-2010, which require additional information to be included on each emergency evacuation diagram. As such, whenever a project refurbishment occurs within any space, existing diagrams throughout the building must be reviewed and updated, if necessary, to suit the IFS standard evacuation diagram template and the current requirements. The upgrade of the diagrams must be included in the consultant/contractor's scope of work for each project.

For existing buildings undergoing refurbishment, the consultant/contractor must request from IFS, the AutoCAD files of the existing emergency evacuation diagrams to update with the revised level layouts, fire equipment locations, and evacuation paths for each level of the refurbishment works. This will require all plans located on each level of the building to be upgraded as part of the project works. To meet the requirements of AS3745-2010, this may include the addition of standardised symbols identifying the location of all WIPs, MCPs, ECPs, OWS Panels, FIPs, Hydrants, Hose reels, Extinguishers and Fire Blankets on the level, and realigning the floor plan and assembly area plan to ensure they are correctly orientated to suit the location of the installed diagram.

Locations of emergency evacuation diagrams, routes of egress, and assembly area locations must be submitted for approval to IFS and the building emergency warden team prior to installation. Generally, these must be located on each level in the vicinity of each fire stair, lift landing and in public areas adjacent to lecture theatres, seminar rooms, teaching laboratories and all teaching and learning spaces. This is to ensure occupants and visitors have access to view the plans. Additionally, an emergency evacuation diagram must be installed adjacent to the FIP/MECP.

Detailed specifications indicating the requirements for the picture frames and mounting details relating to the installation of the emergency evacuation diagrams can be obtained from IFS.

### 5.12 EXIT SIGNS

Exit lighting must be installed to suit the requirements of the NCC. Technical information and requirements regarding exit lighting are included in the IFS document UON-ESS-104 Emergency Escape Lighting and Illuminated Exit Signage.

Further information can be found in the IFS document Signage Guideline.

### 5.13 FIRE DAMPERS

All fire dampers installed must be:

- a. Provided with access panels to enable inspection, testing, and resetting of the damper
- b. Detailed on the building asset register.
- c. Included in a consolidated Passive Fire and Smoke Containment System report for the project works. The report will provide comprehensive details of all items listed under Section 12 of AS1851-2012, including:
  - i. consolidated as-built fire compartmentation drawings for each area and level of the building affected by the project works, documenting the exact location of all existing and new fire walls, floors, and ceilings, together with the location of all existing and new passive fire and smoke containment measures
  - ii. corresponding photos of each individual passive fire and smoke containment measure
  - iii. certification of each individual passive fire and smoke containment measure

### 5.14 FIRE / EGRESS DOORS

A number of existing fire doors located within the University are old and may contain an asbestos core. Any doors thought to contain asbestos must be inspected prior to works commencing by performing a hazardous materials inspection of the proposed site. This inspection will be performed by the project consultant/contractor.

If any doors located in a proposed refurbishment area are confirmed to contain asbestos, the door must be removed in line with SafeWork NSW asbestos removal requirements and be replaced with a new door to suit the current requirements. All asbestos removal and disposal must be carried out by a suitably licensed asbestos contractor in accordance with the relevant State and Federal WHS Acts and Regulations, and in accordance with the University and IFS OHS Management System.

All doors/fire doors located in egress paths within a proposed refurbishment area of an existing building must be upgraded as part of the project refurbishment works to comply with current NCC and Australian Standard requirements. This includes:

- a. Statutory signage must be provided in accordance with requirements of the NCC. Note that signage must be fixed to fire door sets with devices that will not penetrate the skin of the door.
- b. New door hardware, including door closers, lever handles and latches and locks must be compliant with the requirements of the NCC and the Environmental Planning and Assessment Regulation.
- c. A compliant door swing, in the direction of egress, is required in accordance with the requirements of the NCC.
- d. The hinges for fire/egress doors must be screwed to the door frame and not welded.
- e. All fire doors and associated frames must be tagged with a test certification label.
- f. If magnetic door holders are required for installation, they must be installed at the top of the door in a position that allows easy access to a separate release button.
- g. Where the opening of a fire/egress door may cause injury to persons on the other side, consideration must be given for the door to be installed complete with an approved and tested viewing panel
- h. Any alterations to existing fire door sets must be provided with full certification from the fire door manufacturer and installer, indicating that the alterations are consistent with the tested

prototype, which has been submitted to the standard fire test procedures. Additionally, new certification tags must be installed on both the door leaf and doorframe.

- i. All information must be detailed on the building asset register.
- j. All information must be included in a consolidated Passive Fire and Smoke Containment System report for the project works. The report will provide comprehensive details of all items listed under Section 12 of AS1851-2012, including:
  - i. consolidated as-built fire compartmentation drawings for each area and level of the building affected by the project works, documenting the exact location of all existing and new fire walls, floors, and ceilings, together with the location of all existing and new passive fire and smoke containment measures.
  - ii. corresponding photos of each individual passive fire and smoke containment measure.
  - iii. certification of each individual passive fire and smoke containment measure.

### **5.15 FIRE HOSE REEL SYSTEMS**

Water supplies for existing fire hose reel systems vary throughout the University, due to the differing ages of the systems and the original standard of performance design and installation of each of the systems. When designing and installing new fire hose reels or upgrading existing systems, the consultant/contractor must test and confirm the existing water supply pressure/flow details to determine compliance with the current NCC and Australian Standard requirements.

Water supplies for fire hose reel systems must be taken from the metered potable cold-water supply and will be piped independently to ensure shutdown of the domestic water supply system does not affect the operation of the fire hose reel system and vice versa. The fire hose reel system pipe work must consist of Type B copper tube and fittings.

Where fire hose reel booster pumps are installed to satisfy the pressure and flow requirements for fire hose reel system, the pump-set must be provided in accordance with the requirements of AS2441. The fire hose reel pump will supply only the fire hose reel system and must not be installed to supply the potable cold-water supply system and vice versa. Pumps shall be housed in a pump room with access in accordance with the NSW fire brigade requirements and AS/NZS 2419.1 and AS/NZS 2941.

All fire hose reels must be provided with 36m hose length and 19mm diameter hose with brass nozzles attached. All installed fire hose reels must have the instructions for operation in graphics rather than written instructions.

For existing building refurbishments, the location and coverage of the existing fire hose reels must be reviewed and upgraded to meet the current NCC and Australian Standard requirements in order to provide compliance with any changes to the new floor layout.

It is University preference for the fire hose reels to be installed in a cupboard whether it is internal or external. Where fire hose reels are located in enclosures or cupboards, signage consistent with the IFS document Signage Guideline must be provided in accordance with requirements of the Australian Standards.

Fire hose reels must only be installed for use in fire situation. The installation of fire hose reels for use in non-fire situations will not be accepted.

Fire hose reel pipe work must be marked using adhesive pipe markers with water flow direction arrows. Hose reel systems must be provided with backflow prevention devices to comply with AS/NZS and Local Authority requirements.

## 5.16 FIRE HYDRANT SYSTEMS

### 5.16.1 General

In cases where the existing fire hydrant system of a refurbished building is not installed to the current regulations and would require substantial upgrading to achieve compliance, the consultant/contractor must consult with IFS, and if appropriate Fire & Rescue NSW, to determine the extent of the proposed alterations to the system.

Wherever possible, fire hydrant coverage for all University buildings is preferred to be achieved by hydrants located external to the building. External fire hydrants will be provided with painted dual hydrant landing valves; the valve assembly and the stem painted signal red. External fire hydrants generally form part of the University water supply network and are therefore considered as “feed” fire hydrants that must not be connected to a building fire brigade booster assembly. Appropriate labelling must be provided on the stem of all external hydrants connected to a building fire brigade booster assembly for the purpose of indicating the “attack” fire hydrant and the booster assembly to which the hydrant is connected.

All fire hydrants are to be fitted with alloy Storz fittings and end caps.

Fire brigade booster assemblies must be located in a position where a fire appliance has adequate access. Block plans located at each fire brigade booster assembly must be upgraded to suit changes to the system due to building refurbishment works. Signage must be provided at each fire brigade booster connection in order to easily identify the building/area served by the booster.

Where fire hydrants are located in enclosures or cupboards, signage must be provided in accordance with requirements of the Australian Standards.

Hydrant booster pumps must be connected to the building FIP and the BMS to allow monitoring and alarms to be provided for pump run and pump fault (including electrical mains failure and low fuel level status). The monitoring of these conditions must also satisfy the requirements to allow the omission of weekly pump testing, as per AS1851-2005.

### 5.16.2 Water Supplies

Fire hydrant water supplies must comply with the following details:

- a. Water supplies for existing fire hydrant systems vary throughout the University, due to the differing ages of the systems and the original standard of performance design and installation of each of the systems. When designing and installing new fire hydrants or upgrading existing systems, the consultant/contractor must test and confirm the existing water supply pressure/flow details to determine compliance with the current NCC and Australian Standard requirements.
- b. The fire hydrant system must be supplied by the Potable water supply from either the University reticulation system, direct from the Local Authority water main or the dedicated fire main. Assessments for the requirement of augmentation to the water supply must be made prior to installation.
- c. The building hydrant demand must be available in addition to the building sprinkler demand to ensure that both systems can operate simultaneously from the water supply provided to the building
- d. All fire services test water must recycle back into the fire system storage tanks or alternatively to water retention tanks, to enable reuse of the testwater.
- e. Fire water supply tanks must be either of concrete construction or stainless-steel panel type, complete with access ladders and lockable manhole covers to allow internal tank inspection and cleaning. Tanks must be complete with internal dividing walls and associated supply and drain connections to allow a minimum of 50%of the required storage capacity to be available

during tank cleaning and maintenance operations. Visual tank water level indicators and high- and low-level alarms connected back to the FIP must be installed. Panel tanks must be installed on raised support beams allowing sufficient access to visually inspect the underside of the base of the tank. A minimum clear distance of 500mm around the walls, base and roof of the panel tank must be provided to allowance maintenance and inspection. Tanks with internal bladders will not be accepted.

- f. Means for performing system flow testing at the booster pump (or the booster connection where no pumps are installed) must be provided. This will include a pressure gauge schedule, which indicates the flow required at the test location in order to satisfy the requirements at the most remote hydrant(s). This includes adequate drainage and any other documentation and equipment required to satisfactorily maintain the fire hydrant system and pump in accordance with AS1851-2005.

### 5.16.3 Pipework and Equipment

Fire hydrant pipework and equipment must comply with the following details:

- a. Fire hydrant system pipework must be HDPE where installed underground.
- b. Above-ground fire hydrant pipework must be galvanized medium weight steel pipe, using roll grooved fittings.
- c. All internal exposed fire hydrant pipework must be painted and marked using adhesive pipe markers with water flow direction arrows.
- d. All fire hydrant pumps, and pump controllers must be equal to those manufactured and supplied by Prime Pumps or KSB Ajax Pumps, or approved equivalent.
- e. Pumps shall be housed in a pump room with access in accordance with the NSW fire brigade requirements and AS/NZS 2419.1 and AS/NZS 2941.
- f. Hydrant systems must be provided with backflow prevention devices to comply with AS/NZS and Local Authority requirements.
- g. All fire hydrants valves and boosters must be provided with forged aluminium Storz hose couplings complete with chain linked cap, to suit Fire & Rescue NSW requirements.

### 5.17 FIRE SEALS PROTECTING OPENING IN FIRE RESISTANT COMPONENTS

All fire seals protecting openings in fire resisting components of each building must be:

- a. Designed and installed to the requirements of an approved system of Specification C3.15 of the BCA
- b. Provided with identification labelling in accordance with the requirements of AS4072.1 Appendix B and AS1851-2005
- c. Detailed on the building asset register.
- d. Included in a consolidated Passive Fire and Smoke Containment System report for the project works. The report must provide comprehensive details of all items listed under Section 12 of AS1851-2012, including:
  - i. consolidated as-built fire compartmentation drawings for each area and level of the building affected by the project works, documenting the exact location of all existing and new fire walls, floors, and ceilings, together with the location of all existing and new passive fire and smoke containment measures
  - ii. corresponding photos of each individual passive fire and smoke containment measure
  - iii. certification of each individual passive fire and smoke containment measure



### 5.18 FIRE SHUTTERS

All fire shutters installed must be:

- a. Designed and installed to the requirements of Specification C3.4 of the BCA to achieve the required FRL
- b. Provided with identification labelling in accordance with the requirements of AS1902.2
- c. Held open with a magnet connected to the building fire detection/fire sprinkler system, which allows the fire shutter to automatically close in fire mode. Adequate access to the magnet must be provided
- d. Provided with fully accessible equipment to provide easy resetting of the fire shutter to its normal position after operation has occurred
- e. Provided with an audible warning device, flashing warning light and signage to enable operation in full accordance with the requirements for sliding fire doors as per Clause C3.6 of the BCA.
- f. Detailed on the building asset register
- g. Included in a consolidated Passive Fire and Smoke Containment System report for the project works. The report must provide comprehensive details of all items listed under Section 12 of AS1851-2012, including:
  - i. consolidated as-built fire compartmentation drawings for each area and level of the building affected by the project works, documenting the exact location of all existing and new fire walls, floors, and ceilings, together with the location of all existing and new passive fire and smoke containment measures
  - ii. corresponding photos of each individual passive fire and smoke containment measure
  - iii. certification of each individual passive fire and smoke containment measure

### 5.19 GASEOUS FIRE SUPPRESSION SYSTEMS

Generally, the University does not recommend the installation of gaseous fire suppression systems, except in cases where every other avenue of fire protection has been scrutinized and/or rejected for a valid reason. Carbon dioxide or non-environmentally friendly fire suppression agent systems must not be considered. Prior to any proposal for a gaseous fire suppression system to be installed, an extensive risk assessment, cost benefit analysis and life cycle costing report must be provided by the consultant/ contractor for IFS approval. If a gaseous fire suppression system is to be installed the system must be equivalent to existing systems fitted at the University.

### 5.20 LIGHTWEIGHT FIRE RATED CONSTRUCTION

All lightweight fire rated construction will be:

- a. Designed and installed to the requirements of Specification C1.8 of the BCA to achieve the required FRL
- b. Provided with identification labelling in accordance with the requirements of AS4072.1 Appendix B and AS1851-2012
- c. Detailed on the building asset register
- d. Included in a consolidated Passive Fire and Smoke Containment System report for the project works. The report must provide comprehensive details of all items listed under Section 12 of AS1851-2012, including:
  - i. consolidated as-built fire compartmentation drawings for each area and level of the building affected by the project works, documenting the exact location of all existing

- and new fire walls, floors, and ceilings, together with the location of all existing and new passive fire and smoke containment measures
- ii. corresponding photos of each individual passive fire and smoke containment measure
  - iii. certification of each individual passive fire and smoke containment measure

### **5.21 MECHANICAL AIR-HANDLING SYSTEM SHUTDOWN**

For all University buildings less than 25m in effective height, all mechanical air handling systems, with the exception of non-ducted individual room A/C units, fume cupboards and approved special purpose systems, must be provided with a fire trip signal to shut down the air handling system on activation of the building fire detection and/or fire sprinkler system. Once the fire detection and/or fire sprinkler alarm has been reset, the mechanical air handling system must also be automatically reset to the correct operating status. Under no circumstances are shunt trips to be installed.

Approved special purpose systems includes systems serving operating theatres, clean rooms and rooms housing high value equipment which may be damaged when the ventilation system is shutdown.

Fire trip cabling and equipment which allows shutdown of mechanical air handling systems must be grouped onto one common isolation control switch located at the FIP. This isolation facility must be totally separated from the individual isolation control switches required for fire trips connected to magnetic door holders and fire trips to security door interfaces. Fire trips to mechanical air handling systems must be normally energised.

The consultant/contractor must provide a fire systems interface matrix that lists all existing and new mechanical air handling system shutdown installed in the area of the project.

Details of all fire trip signals and connections provided to shutdown of mechanical air handling systems will be included on the building asset register and associated drawings.

All fire trip status must be monitored and displayed on the BMS.

### **5.22 PORTABLE FIRE EXTINGUISHERS & FIRE BLANKETS**

Fire extinguishers must be installed in all University buildings. Fire extinguisher types and locations must be selected to comply with the coverage and spacing requirements of AS2444, AS1940 and AS2243.8. These Australian Standard requirements exceed those of the NCC.

Generally, dry chemical AB(E) fire extinguishers will be installed due to the suitability with a variety of different class fires. Dry chemical Class D fire extinguishers should be installed in the vicinity of lithium ion batteries such as an electric vehicle charging station. Where a clean fire extinguishing agent is required to protect against electrical fire hazards (Class E), such as lift motor rooms, main electrical switch rooms, main computer server rooms and communications rooms, carbon dioxide extinguishers must be installed.

Wet chemical fire extinguishers must be installed in new or refurbished kitchen areas that include a deep fryer.

Water extinguishers must be installed in all buildings that are not protected with a fire hose reel system.

Where possible, fire extinguishers must be located within fire hose reel cupboards. All extinguishers must be mounted no greater than 900mm above the floor. Where extinguishers are located in enclosures or cupboards, signage must be provided in accordance with requirements of the Australian Standards.

Where refurbishment projects alter or add a risk, the existing fire extinguishers must be replaced or supplemented to cover the new circumstances created. This requirement is to extend to passageways and corridors and to the extinguisher serving the refurbished area.

Prior to project works commencing, the consultant/contractor must perform a dilapidation report of the project site, listing the numbers and types of existing fire extinguishers. These extinguishers must remain in the project site under the control of the contractor throughout the duration of the project works and depending upon suitable condition, appearance and a requirement to install each individual extinguisher, will be either reinstalled, returned to the University or destroyed at completion of the project refurbishment. Existing fire extinguishers that are more than 20 years old must be replaced with new and not reinstalled as part of the project works.

Fire blankets must be installed for use on small fires involving chemicals, cooking oils and fats. These will be located in all wet labs and kitchen areas.

In addition to the above listed requirements, the following portable fire equipment must be installed inside all wet labs, adjacent to the main entry/egress door to the space:

- a. 1 off 3.5kg CO2 extinguisher, minimum 5B(E) rating
- b. 1 off 1200x1200 fire blanket
- c. For larger and higher risk labs, additional extinguishers may be required to be installed within the space. The recommended extinguishers in these circumstances are a 4.5kg AB(E) type dry powder extinguishers installed adjacent to the above listed fire equipment.

### **5.23 PRESSURISING SYSTEMS**

The consultant/contractor must provide a fire systems interface matrix that lists all existing and new required pressuring systems installed in the area of the project.

Details of all required fire safety measures relating to pressuring systems will be included on the building asset register and the associated drawings.

### **5.24 REQUIRED POWER OPERATED EXIT DOORS**

Required power operated exit doors include automatic sliding doors and powered operated door openers/closers which are required to activate when a fire/smoke condition is sensed via the building fire sprinkler or fire detection system. The consultant/contractor must ensure all power operated exit doors installed in required paths of egress automatically open in the event of fire alarm activation.

These devices will be normally energised to enable the devices to return to the fail-safe position when power to the device is lost. To ensure that power operated exit doors are able to be classified as fail- safe devices, fire trip cabling must run from the FIP/sprinkler system pressure switch and connect directly to the door interface and not via any electronic security system controllers, unless the electronic security system controller, cabling and associated equipment are designated as a fail-safe device.

Fire trip cabling and equipment allowing required power operated exit doors and security door interfaces to function will be grouped onto one common isolation control switch located at the FIP. This isolation facility must be totally separated from the individual isolation control switches required for fire trips connected to magnetic door holders and also to shut down mechanical air handling systems.

The consultant/contractor must provide a fire systems interface matrix that lists all existing and new power operated exit doors installed in the area of the project.

All power operated exit doors provided with a fire trip must also be provided with a push button “door release” fixed to the wall adjacent to the door. This requirement is to ensure egress through the door is available in the event of all types of emergencies.

The details of all fire trips to power operated exit doors must be included on the building asset register and the associated drawings.

### **5.25 SMOKE & HEAT VENTS**

The consultant/contractor must provide a fire systems interface matrix that lists all existing and new required smoke and heat vents installed in the area of the project.

Details of all required fire safety measures relating to smoke and heat vents must be included on the building asset register and the associated drawings.

### **5.26 SMOKE & HEAT ALARM SYSTEMS**

Where a University building is not protected or not proposed to be protected with an Automatic Fire Detection and Alarm System or a Fire Sprinkler System, smoke and heat alarms must be installed (except buildings designated as NCC Class 10 structures). Smoke alarms must be installed to suit the spacing requirements of AS1670.1, the Environmental Planning & Assessment Regulation 2000, the NCC and AS3786.

Where smoke and heat alarms are installed, they must be interconnected throughout the building, have LED indicators, have a single test/silencing/hush facility and be 240V mains powered connected to their own dedicated power circuit.

Where smoke alarms are installed in residential and shared accommodation buildings, the smoke alarm must be a photoelectric type and where required, will be provided with an approved relay output facility to activate lighting to assist evacuation in accordance with the requirements of the NCC Volume 2 Clause 3.7.2.5.

The University preferred brand of smoke and heat alarms is Brooks or approved equivalent.

### **5.27 SMOKE DAMPERS**

All smoke dampers installed will be:

- a. Provided with access panels to enable inspection, testing, and resetting of the damper
- b. Detailed on the building asset register.
- c. Included in a consolidated Passive Fire and Smoke Containment System report for the project works. The report must provide comprehensive details of all items listed under Section 12 of AS1851-2012, including:
  - i. consolidated as-built fire compartmentation drawings for each area and level of the building affected by the project works, documenting the exact location of all existing and new fire walls, floors, and ceilings, together with the location of all existing and new passive fire and smoke containment measures
  - ii. corresponding photos of each individual passive fire and smoke containment measure
  - iii. certification of each individual passive fire and smoke containment measure

### **5.28 SMOKE DOORS**

Smoke doors must be constructed so that smoke will not pass from one side of the doorway to another, in accordance with the requirements of BCA Specification C3.4. This includes doorways located in smoke walls and also doors suitably sealed against smoke spreading from enclosures located in exits and paths of travel which contain electrical and communication distribution boards/equipment. See IFS document UON-ESS-102 Distribution Board Specification for further information.

All smoke doors must:

- a. Be provided with statutory signage in accordance with the BCA Clause D2.23. All signage must be consistent with the IFS document Signage Guideline.
- b. Swing in the direction of egress, or in both directions
- c. Fitted with smoke seals capable of resisting smoke to the required temperature/time requirements of AS6905- 2007
- d. If magnetic door holders are required to be installed, they will be installed at the top of the door in a position that allows easy access to the release button.
- e. Where the opening of a smoke door may cause injury to persons on the other side, consideration must be given for the door to be installed complete with an approved and tested viewing panel
- f. Any alterations to existing smoke door sets must be provided with full certification from the door manufacturer indicating that the alterations are consistent with the tested prototype that has been submitted to the standard fire test procedures. Additionally, new certification tags must be installed on both the door leaf and door frame.
- g. Detailed on the building asset register
- h. Included in a consolidated Passive Fire and Smoke Containment System report for the project works. The report must provide comprehensive details of all items listed under Section 12 of AS1851-2012, including:
  - i. consolidated as-built fire compartmentation drawings for each area and level of the building affected by the project works, documenting the exact location of all existing and new fire walls, floors, and ceilings, together with the location of all existing and new passive fire and smoke containment measures
  - ii. corresponding photos of each individual passive fire and smoke containment measure certification of each individual passive fire and smoke containment measure

### **5.29 STANDBY POWER SYSTEMSTANDBY POWER SYSTEMS**

Standby power systems are generally installed to meet the NCC requirements for Atrium Construction and for aisle/step lighting in theatres.

Where standby power systems are installed for aisle and step lighting requirements, a central UPS will be installed. The UPS must be located in a secured area that allows maintenance by authorised personnel. The UPS must be hard-wired and secured in a lockable cabinet that provides adequate ventilation. Appropriate signage must be provided to the cabinet housing the UPS.

Further technical information and requirements regarding standby power systems may be found in the IFS document UON-ESS-106 Generators and Emergency Power Supplies.

### **5.30 WALL WETTING SPRINKLER & DRENCHERS SYSTEMS**

Wall wetting sprinkler and drencher systems must be installed in accordance with the NCC to provide protection over windows, openings, or walls of non-fire-resistant construction. External wall wetting sprinklers will be provided to protect against fire exposure to/from adjacent buildings and internal wall wetting sprinklers must be provided to protect required paths of egress. Where wall wetting sprinklers are installed to protect windows, the windows must be permanently fixed in the closed position.

Water supplies for existing wall wetting sprinkler and drencher systems vary throughout the University, due to the differing ages of the systems and the original standard of performance for each of the systems. Examples of system water supplies include connections to building fire sprinkler systems, individual systems

complete with dedicated sprinkler valve sets and pumps, systems connected to fire hydrant/fire hose reel system pipework and systems connected to domestic water supplies.

When designing and installing new wall wetting sprinklers, or upgrading existing systems, the consultant/contractor must test and confirm the existing water supply pressure/flow details to determine compliance with the current NCC and Australian Standard requirements.

Dedicated sprinkler valve sets must be installed for wall wetting sprinkler and drencher systems with more than 12 sprinkler heads. These systems must be connected to the building FIP.

### **5.31 WARNING & OPERATIONAL SIGNS**

Warning and operational signs include:

- a. Fire safety notices indicating “Offence Relating to Fire Exits” as per the Environmental Planning & Assessment Regulation
- b. Fire/smoke/egress door signage as per NCC Clause D2.23
- c. Signage warning against the use of lifts in fire as per NCC Clause E3.3.

Fire stairs and exits that require the installation of fire safety notices indicating “Offence Relating to Fire Exits” must have the notice displayed in a conspicuous position adjacent to the doorway providing access to the exit, but not within the exit.

Signage warning against the use of lifts in fire must be displayed adjacent to every lift call button throughout the building.

### **5.32 EQUIPMENT LABELLING AND IDENTIFICATION**

#### **5.32.1 Below-Ground Services**

All underground services are to have marking tape of correct distances above pipework complying with relevant Australian Standards for that service. Where the service is non-metallic, provide a tape incorporating locating wire.

#### **5.32.2 Above-Ground Services**

All pipework and cabling must be labelled with adhesive markers indicating pipe contents or system type and directional arrows indicating flow. Markers must be installed at a minimum of every five meters.

Labelling must not be restricted only to close proximity of access panel openings.

#### **5.32.3 Asset Labelling and Barcoding**

Equipment must be provided with asset labels and bar codes as per IFS document Engineering Services Briefing Document. For any queries regarding the labelling of assets, contact IFS.

### **5.33 PIPEWORK AND CABLING INSTALLATIONS**

#### **5.33.1 Below-Ground Services**

All pipework and cabling installed below ground must be fully surveyed and documented in accordance with the details required for Quality Level A, as per AS5488-2013 – Classification of Subsurface Utility Information (SUI).

The IFS Standard – Excavation Permit Form must be submitted and approved by IFS prior to installing or repairing any pipework or cabling located below ground.

### 5.33.2 Above-Ground Services

All pipework and cabling installations, including the materials, supports, jointing, etc., must satisfy the relevant Australian Standard and IFS documents UON-ESS-101 General Electrical Specification, and Engineering Services Briefing Document.

### 5.33.3 Core Holes and Sleeves

Details of all proposed core holes in floors, walls, beams, and columns must be checked and approved by an IFS representative prior to coring the hole.

All pipework and cabling passing through a core hole or masonry/concrete wall or floor must be provided with a 0.6 mm thickness sheet copper sleeve having a grooved and seamed joint. Sleeves must be cylindrical having a diameter to provide a 25mm gap all around the services passing through the sleeve. Alternatively, copper tubing may be used as the sleeve if a 25mm gap around the service cannot be achieved. Each service passing through the sleeve must be positioned centrally in the sleeve to ensure the annular space between the service and the sleeve is equal and round.

Fire rating of all pipe and cabling penetrations must be installed to comply with all statutory requirements and the requirements of this standard.

### 5.33.4 Corrosion Protection and Finishes

All surfaces exposed or susceptible to corrosion will be suitably painted, including external surfaces of all machinery, apparatus, equipment, fittings, tanks, vessels, and services including supports, hangers, and brackets.

Ferrous metal exposed to the atmosphere or in humid conditions is to be hot dip galvanised having a minimum coating thickness 0.1mm. Hot dip galvanising must be carried out after all welding, cutting, drilling and swarf removal has been completed. The university will not accept cold galvanising process.

Surfaces that must not be painted include:

- a. All fiberglass and plastic surfaces.
- b. Chrome plated and stainless-steel surfaces.
- c. Bearing surfaces, slides, adjusting screws and any surface that is required to be unpainted for the correct operation or adjustment of the equipment.
- d. Flexible duct connections to plant, rubber or canvas hoses, flexible rubber mountings and any other non-metallic flexible connections.
- e. Piping where installed in ceilings, trenches, underfloor, and similar concealed spaces must not be painted throughout their entire length but must be labelled with identification bands. However, steel piping installed in damp conditions in any of the above must be hot dip galvanised.
- f. Bare copper tanks.
- g. Motor and equipment nameplates.

## 6 COMMISSIONING

Comprehensive pre-commissioning, commissioning and quality monitoring must be specified by the consultant/designer.

A project specific commissioning plan is to be developed and provided to the University for review and approval.

Detailed testing and commissioning records must be provided for each system and each component as appropriate. All such records must be witnessed and verified by the project consultant/head contractor.

Project hand over inspection and testing plans (ITPs) must be developed by the consultant/contractor to allow the system to be handed over to the University. The ITPs must include witness testing by university representatives of smoke detectors/WIP's/EWIS will be undertaken (random sample of devices on each floor), flow/pressure/control test & demonstration of operation of fire pumps etc.

## **7 SAFETY IN DESIGN**

The contractor must consider risk during the design. A design safety report must be submitted to the relevant IFS Project Manager for every design project. Contractors must confirm, so far as is reasonably practicable (SFAIRP), that the structure is without risks to health and safety.

Design risks must be considered for the asset lifecycle covering construction, operation and maintenance, refurbishments, and decommissioning.

The design safety report must include the following:

- a. Description of design element.
- b. Description of potential risks and hazards associated with the design element.
- c. A low/medium/high risk assessment considering likelihood and consequence.
- d. Proposed measures to eliminate risks where practicable.
- e. Control measures to mitigate and manage design risks.
- f. Nominating responsibilities for managing the design risks.

This may be provided as a design risk register where appropriate and must include results of any calculations, testing and analysis etc.

## **8 DOCUMENTATION & RECORDS**

### **8.1 DESIGN DOCUMENTATION**

Prior to commencing construction of new or refurbishment projects, the consultant/contractor must fully investigate and document the requirements for each essential fire safety system required to be installed, altered, or modified as part of the project works.

This must include:

- a. Review of the current Annual Fire Safety Statement (AFSS) for the building to determine the proposed Fire Upgrade Strategy.
- b. Provision of a BCA Compliance Report.
- c. Provision of Fire Engineered Alternative Solution Report (where applicable).
- d. Return Brief defining the systems proposed and any deviations from this standard.
- e. Calculations to be provided on the sizing of the pipe work. Future allowances are to be included in these calculations\ sizing.
- f. Calculations & selections on the proposed equipment.
- g. Budget calculations.
- h. Provision of Design Certification of each essential fire safety measure.

This documentation must be provided by the consultant/contractor in both electronic and hard copy formats and approved by the University.



## 8.2 COMPLETION DOCUMENTS

At the completion of all projects, the following documentation must be provided for each essential fire safety measures installed or altered as part of the project works:

- a. O&M manual(s)
- b. As-built drawings (including schematics, block plans, and fire system matrix formatted as per Attachment 4 - Fire Detection System Matrix)
- c. Final Fire Safety Certification (indicating BCA clauses & Australian Standards year/amendment)
- d. Asset schedules and labelling (as per the Asset Identification and Labelling Standard)
- e. Commissioning test results
- f. Product manufacturer specific information
- g. Copies of FIP, MECP, FMS, MNS, computerised emergency and exit lighting system programs and graphics computer software modifications
- h. Licensed versions of FIP, MECP, FMS, MNS, computerised emergency and exit lighting system graphics computer software required to program panels and monitoring systems. (Inclusive of a hard copy of the fire panel program. Please refer to Attachment 5 - Fire Detection System Program for indicative formatting and content)
- i. Details of all usernames and passwords required to access all equipment and software
- j. Warranty schedules for all major items of equipment, including but not limited to tanks, pumps, FIP's, MECP's, etc.
- k. Maintenance requirements for all items of equipment
- l. Building User Guide
- m. Installers Statutory certificates

This documentation must be provided by the contractor in both electronic and hard copy formats and approved by the University prior to Practical Completion being granted.

Similar completion documentation must be provided by the Fire Safety Engineer, in the form of a Fire Safety Strategy Handover Report, confirming full details of certification, commissioning and specific ongoing maintenance and operational management issues required for all approved Alternative Solutions.

## 9 OPERATIONS

### 9.1 MATERIALS AND EQUIPMENT SELECTION

Only new materials, equipment and components will be installed, and these must be of good quality, fit for purpose and selected to minimise life-cycle costs and maximise efficiency. All products must be supported locally and internationally by factory trained service networks. All spare parts must be available ex-stock factory for a period of 10 years from purchase date. Equipment and materials that are obsolete, discontinued, about to be discontinued or superseded, must not be installed. Selected equipment must have the ability to be backwards compatible.

Uniformity of the type of materials must be consistent throughout all individual installations and must match or be fully compatible with the existing equipment.

All fire protection equipment must be designed and manufactured to the relevant Australian Standards and be listed in the ActiFire Register of Fire Protection Equipment.

Details of all major items of fire equipment proposed to be installed during new or refurbishment projects must be submitted to IFS for approval prior to installation. This will include, but is not limited to, pipe material selection, FIPs, MECPs, fire pumps, fire water storage tanks, etc.

Identification of a proprietary item of equipment will not necessarily imply exclusive preference for the item identified but indicates a deemed-to-comply item.

## **9.2 SERVICE ACCESS REQUIREMENTS**

The following servicing and access requirements must be provided:

- a. Position all equipment and arrange access provisions at equipment, to optimise future maintenance and repairs.
- b. Service access doors and panels must be hinged and lockable with a University plantroom surrogate key (SK). Lift off panels with screw fixings are not acceptable
- c. The University will not accept major plant within ceiling spaces and plant in tight spaces. Plant that is in a ceiling space must have free and easy access. This includes ability to service system without reaching around or over columns, beams, cable trays, pipe work, lights, and duct work
- d. All motors are to be provided with isolators within 3 meters distance from motor. Isolators must be labelled with details of the source of electrical supply (DB/CB). A plus 20% additional dimension access allowance is to be provided for above the manufacturers access requirements
- e. Major plant located above 3m height will have permanent stair/ladder access provisions with permanent workable platform
- f. Trip hazards to be identified and painted in yellow
- g. Electrical hazards must be identified and labelled appropriately
- h. Confined spaces to be noted and appropriate signage applied
- i. Fixed switchable lights are to be provided in all areas where essential fire safety measures are installed
- j. Access to plant and equipment must comply with all WHS regulations

## **9.3 REDUNDANT EQUIPMENT**

All redundant essential fire safety systems and equipment and associated services (power, water, drainage, etc) must be removed as part of the project. Building surfaces and finishes must be made good wherever redundant services are removed. Where a service is unable to be removed appropriate tags and labelling shall be installed to indicate the service is redundant.

## **9.4 INTERRUPTION TO ESSENTIAL FIRE SAFETY MEASURES**

Where any new, refurbishment or maintenance works require interruption or isolation of essential fire safety measures to prevent false alarms from occurring or to allow work to be performed on the system, contractors must gain approval from IFS prior to the works occurring.

An application for "Fire System Impairment" form must be submitted to IFS for approval at least 72 hours prior to any proposed interruption.

When refurbishment works occur within occupied buildings, fire safety measures in occupied areas must not be interrupted or isolated for periods longer than eight (8) hours. Wherever possible, the existing fire safety measures installed in project areas will be disabled throughout the construction period.

Where the project works require isolation of fire safety measures serving occupied areas of the building outside of the refurbishment area, the University's current maintenance provider must be used to isolate and de-isolate the system on a daily basis to minimise system downtime and ensure that the building has adequate fire safety measures available.

To prevent fire detector contamination caused by construction and maintenance activities, detector dust caps must be temporarily installed on all detectors in the vicinity of all dusty works. Where dust caps are temporarily installed, the contractor must adopt a system to check and notify the University for both the installation and removal of the dust caps.

Prior to refurbishment works commencing within buildings proposed to remain occupied during the refurbishment works, the contractor must consult with IFS the proposed strategy and methodology relating to interruption of essential fire safety measures within the building for the duration of the project works. The contractor must also provide appropriate safe work method statements (SWMS).

All costs associated with the interruption and isolation of essential fire safety measures required for new and refurbishment projects will be included by the contractor in the overall tendered amount for the project works.

Where construction works cause false alarms, all applicable false alarms fees and maintenance contractors' attendance to the false alarms, must be paid for by the project.

## **9.5 MAINTENANCE & TESTING**

For essential fire safety measures installed as part of a refurbishment project of an existing building, regular statutory maintenance and testing must be carried out by the University essential services maintenance contractor during the Defects Liability Period (DLP). The installation contractor must provide a comprehensive handover and the required completion documentation at Practical Completion.

All defects arising from regular statutory maintenance and testing performed during the DLP will be documented and passed onto the installation contractor for rectification. The installation contractor must be responsible for all defect rectification works identified during the DLP.

For new buildings, the installation contractor must provide statutory maintenance and testing of all essential fire safety measures listed on the Final Fire Safety Certificate for the building, throughout the DLP. Prior to the completion of the DLP, the installation contractor will perform all annual maintenance procedures in the presence of the University essential services maintenance contractor and provide documentation confirming the provision of all statutory maintenance has been performed during the DLP. In these instances, the installation contractor must also provide certification in the form of an Annual Fire Safety Statement prior to completion of the DLP.

Any details which will affect the future maintenance and performance of the new or upgraded equipment must be supplied by the installation contractor at Practical Completion.

Prior to completion of the DLP, a final inspection of the installed systems will be carried out by the: installation contractor, appropriate IFS staff, and University essential services maintenance contractor, in order to reconcile the performance of the equipment during DLP to produce a final list of project defects. All project defects identified must be rectified by the installation contractor prior to finalisation of the DLP.

## 10 AUTHORISATION OF VARIATIONS

Project managers, consultants, contractors, commissioning agents and facilities maintenance personnel must ensure compliance with these requirements is achieved.

Variations to this standard must only be considered where:

- a. the University Standard's requirement cannot physically or technically be achieved.
- b. the alternative solution delivers demonstrated and proven superior performance for the same capital and life cycle cost or better.

Consultants and contractors must identify and justify requirements of the standard that do not apply to the project or which need to be varied. The issuer of this standard or their delegated authority must review and consider requirements of stakeholders from clients, projects, and facilities management before deciding whether to approve variations. Their formal sign-off is required for acceptance of any non-compliances and departures from this standard's requirements.

## 11 QUALITY CONTROL

### 11.1 DESIGN STANDARD COMPLIANCE

Compliance with requirements of this standard must be checked throughout the design, construction and commissioning phases of projects by IFS' services consultant. Any issues or deviations from this standard must be reviewed and approved in writing by the issuer of this standard.

Competent IFS consultants and representatives must check compliance with this standard during design reviews and formal site inspections. Any non-conformances with requirements of this standard must be documented and provided to the IFS Project Manager for issue to contractors and their consultants.

Project Managers must maintain a formal register of non-conformances and manage close out of outstanding non-conformances. Contractors and their consultants issued with non-conformances must take appropriate corrective actions. The IFS Project Manager must ensure:

- a. proposed corrective actions are implemented
- b. close out of non-conformances in relation to this standard is formally approved and signed off by the author of the standard or their delegate

### 11.2 DESIGN STANDARD CERTIFICATION

Contractors and consultants must certify compliance to the design standard at each of the following project phases:

- a. Design and Documentation
- b. Tender
- c. Construction

Notwithstanding IFS' internal quality control processes, contractors and their consultants must implement their own robust quality assurance and control procedures to ensure compliance with requirements of this standard.

### 11.3 CONSTRUCTION COMPLIANCE

Consultants and contractors are expected to include check sheets for each system component detailing each item that needs to be checked, tested, and verified during the installation process. Such check sheets must

be completed and verified by the project consultant/contractors, including the identification of any defects and the closing out of such defects.

#### **11.4 ACCEPTANCE**

The University will only accept projects as complete when all the above have been carried out, submitted, and verified.

## **12 ACKNOWLEDGEMENTS**

The University of Newcastle would like to acknowledge and thank the University of Sydney for their assistance in the development of this document.

## 13 REFERENCES

Design and documentation utilising these standards are to incorporate the requirements of the following current standards and requirements as a minimum:

- a. National Construction Code
- b. Environmental Planning & Assessment Regulation
- c. Work Health & Safety Act
- d. All IFS Standards
- e. AS1074 Steel tubes and tubular for ordinary service
- f. AS 1221 Fire Hose Reels
- g. AS1530.1 Methods for fire tests on building materials, components, and structures – Combustibility test for materials
- h. AS1530.2 Methods for fire tests on building materials, components, and structures – Test for flammability of materials
- i. AS1530.3 Methods for fire tests on building materials, components, and structures – Simultaneous determination of ignitability, flame propagation, heat release and smoke release
- j. AS1530.4 Methods for fire tests on building materials, components, and structures – Fire resistance test of elements of building construction
- k. AS 1668.1 The use of mechanical ventilation and air conditioning in building - Fire and smoke control
- l. AS 1670.1 Fire detection, warning, control, and intercom systems – System Design, installation, and commissioning – Part 1: Fire
- m. AS 1670.4 Fire detection, warning, control, and intercom systems – System Design, installation, and commissioning – Part 4: Sound Systems and Intercom Systems for Emergency Purposes
- n. AS 1851 Maintenance of fire protection systems and equipment
- o. AS 1905.1 Fire resistant door sets
- p. AS 1905.2 Fire resistant roller shutters
- q. AS 1940 The storage and handling of flammable and combustible liquids
- r. AS 2118.1 Automatic fire sprinkler systems - General systems
- s. AS 2118.6 Automatic fire sprinkler systems – Combined sprinkler and hydrant
- t. AS 2243 Safety in laboratories - Planning and operational aspects
- u. AS 2243.8 Safety in laboratories – fume cupboards
- v. AS 2293.1 Emergency evacuation lighting for buildings – System design, installation, and operation
- w. AS2304 Water storage tanks for fire protection systems
- x. AS 2419.1 Fire Hydrant installations – System design, installation, and commissioning
- y. AS 2441 Installation of fire hose reels
- z. AS 2444 Portable fire extinguishers and fire blankets – Selection and location.
- aa. AS 2941 Fixed fire protection installations - Pumpset systems
- bb. AS 3000 Electrical installations
- cc. AS 3013 Electrical installations- classification of the fire and mechanical performance of wiring system elements
- dd. AS 3500 - National plumbing and drainage code
- ee. AS 3786 Smoke alarms.
- ff. AS 4072 Components for the protection of openings in fire-resistant separating elements - Service penetrations and control joints
- gg. AS4428.1 Fire detection, warning, control, and intercom systems – Control and indicating equipment – Fire

- hh. AS 5007 Powered doors for pedestrian access and egress
- ii. AS 6905 Smoke doors
- jj. AS/CA S009:2013 Installation requirements for customer cabling – Wiring rules
- kk. National Code of Practice for the Safe Removal of Asbestos (NOHSC:2002 -1988)

The above standards are not an exhaustive list of the relevant requirements. The consultant/contractor must incorporate all relevant standards and Authorities requirements into project specific design, documentation, and installation.

Consideration must be given by the consultant/contractor to the original standard of performance relevant to the construction date of the individual essential fire safety measures.

## **14 ATTACHMENTS**

ATTACHMENT 1	Design and Construct Checklist for Consultants
ATTACHMENT 2	Callaghan Fire System Network Topology (FIP Loops)
ATTACHMENT 3	MX1 Loop Inputs
ATTACHMENT 4	MX1 Phone Line Connections
ATTACHMENT 5	Pseudo Points
ATTACHMENT 6	Mass Notification Networking (VOIP)
ATTACHMENT 7	Fire Detection System Matrix (Formatting Reference)
ATTACHMENT 8	Fire Detection System Program (Formatting Reference)
ATTACHMENT 9	Small Fibre Enclosure
ATTACHMENT 10	Large Fire Enclosure
ATTACHMENT 11	Fire Rated Cable
ATTACHMENT 12	Fire Rated Fibre Optical Cable Colour Code

## ATTACHMENT 1 DESIGN AND CONSTRUCT CHECKLIST FOR CONSULTANTS

### Design and Construct List

The following is a list of fire documents which IFS require the building service consultant and contractors to provide as part of their package.

This is a guide for the consultant/contractor to ensure they meet minimum design components in all projects. These documents will be reviewed by the relevant IFS Services Engineer or their delegate during the design phases. This list does not alleviate the building services consultant's responsibility to design to the online IFS Design standards.

sign input - Provided by all Fire Services Consultants on all Projects		Phase 1	Phase 2	Phase 3	Phase 4	Phase 5	Phase 6		
Item Required	Detail of the Design Item to be Completed	Project Planning and Assessment	Approved Project Initiation	Design and Documentation	Tender	Construction	Post Construction and DLP	Compliance Achieved	Building Services Consultant Comments
Application for connection to hydraulic services infrastructure for new or increased water supply requirements.	Application to be made to either Hunter Water or University of Newcastle (determined by ownership). Application must be approved prior to design being finalised.		x					Yes / No or N/A	
Specifications (Where applicable)	Complete a fire specification for the project. Include schedules for all major items of equipment including FIP, EWIS, pumps, tanks, and material types.			x				Yes / No or N/A	
Plan Layout Drawings	Design drawings in AutoCAD (and Revit 3D model where applicable) format including plans, schematics, and single line diagrams.			x		x		Yes / No or N/A	
Room Spatial Allowances with Fire Equipment	Confirm all equipment proposed will fit within the room/riser/ceiling spaces with enough access for maintenance and egress.			x		x		Yes / No or N/A	
BMS & future MNS Connections	Proposed connections, interfacing, system programming, graphic upgrades, and network communications between building systems and BMS to be submitted for approval.			x		x		Yes / No or N/A	
Water Supply Pressure/Flow Calculations	Provide details of existing water supply pressure/flow requirements via Hunter Water enquiry or by testing the actual supply characteristics and providing results. Water supply graphs (town main + pumped) to be provided to indicate hydrant and fire systems combined water supply design requirements.			x		x		Yes / No or N/A	
Equipment sizing	Calculations & selections to be provided for all proposed equipment including pumps, tanks, FIP's, MECP's. Future allowances are to be included in these calculations/sizing.			x		x			



sign Input - Provided by all Fire Services Consultants on all Projects		Phase 1	Phase 2	Phase 3	Phase 4	Phase 5	Phase 6		
Item Required	Detail of the Design Item to be Completed	Project Planning and Assessment	Approved Project Initiation	Design and Documentation	Tender	Construction	Post Construction and DLP	Compliance Achieved	Building Services Consultant Comments
Supply of statutory design certifications and certifications of compliance to the University standards and other relevant standards.	Complete the design certificate in line with the relevant standards and requirements including NCC, Australian Standards, Fire Engineering Report, IFS Standards			x	x	x		Yes / No or N/A	
Safety in Design Documentation	Provide a Safety in Design document for review and approval by the Services Engineer.			x	x	x	x	Yes / No or N/A	
Interface Matrix & Block Plans	Interface matrix and block plans proposed to be installed to be submitted for approval prior to installation					x		Yes / No or N/A	
Evacuation Diagrams	Evacuation diagrams proposed to be installed to be submitted for approval prior to installation					x		Yes / No or N/A	
Asset List	Proposed final asset list to be submitted for approval					x		Yes / No or N/A	
Inspection, testing and maintenance	Confirm all inspection, testing and preventive maintenance to be performed during DLP together with proposed dates when the tasks will be performed						x	Yes / No or N/A	

Note that the different phases of design and construct project timelines are to be determined by the University project manager.

# ATTACHMENT 2 CALLAGHAN FIRE SYSTEM NETWORK TOPOLOGY (FIP LOOPS)

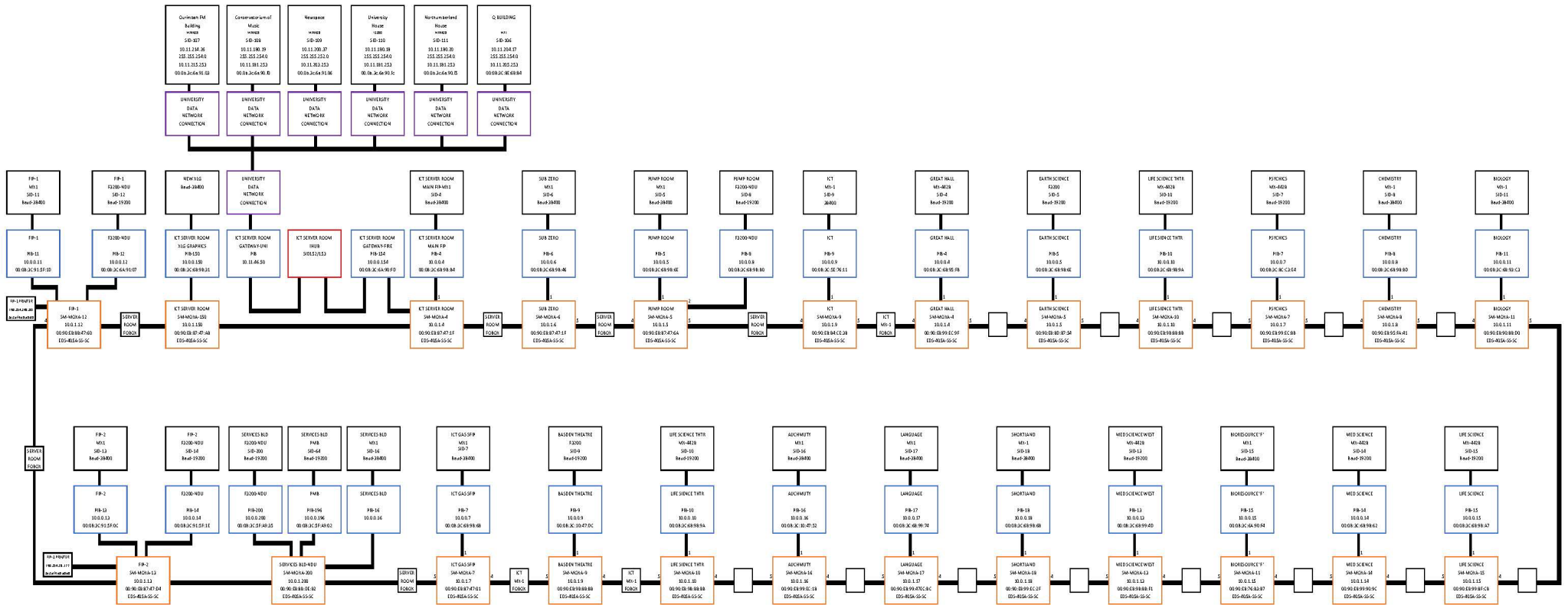

### ATTACHMENT 3      MX1 LOOP INPUTS

ADDR.	Type	Zone	Description
1.1.0	DIM800		
1.1.1	Input 1	3	ICT BUILDING
1.1.2	Input 2	4	GREAT HALL
1.1.3	LED		
2.1.0	DIM800		
2.1.1	Input 1	5	EARTH SCIENCE
2.1.2	Input 2	6	SCIENCE LECTURE THEATRE
2.1.3	LED		
3.1.0	DIM800		
3.1.1	Input 1	7	PHYSICS
3.1.2	Input 2	8	CHEMISTRY & SCIENCE
3.1.3	LED		
4.1.0	DIM800		
4.1.1	Input 1	9	BASDEN LECTURE THEATRE
4.1.2	Input 2	10	LIFE SCIENCE THEATRE
4.1.3	LED		
5.1.0	DIM800		
5.1.1	Input 1	11	BIOLOGICAL SCIENCES
5.1.2	Input 2	13	MEDICAL SCIENCE WEST
5.1.3	LED		
6.1.0	DIM800		
6.1.1	Input 1	14	MEDICAL SCIENCES
6.1.2	Input 2	15	LIFE SCIENCES
6.1.3	LED		
7.1.0	DIM800		
7.1.1	Input 1	16	AUCHMUTY LIBRARY
7.1.2	Input 2	17	LANGUAGE CENTRE
7.1.3	LED		
8.1.0	DIM800		
8.1.1	Input 1	18	SHORTLAND UNION BUILDING

ADDR.	Type	Zone	Description
8.1.2	Input 2	19	GENERAL PURPOSE BUILDING
8.1.3	LED		
9.1.0	DIM800		
9.1.1	Input 1	20	SOCIAL SCIENCES
9.1.2	Input 2	21	DRAMA STUDIO
9.1.3	LED		
10.1.0	DIM800		
10.1.1	Input 1	22	DRAMA BUILDING
10.1.2	Input 2	24	BEHAVIOURAL SCIENCES
10.1.3	LED		
11.1.0	DIM800		
11.1.1	Input 1	25	MATHEMATICS
11.1.2	Input 2	26	COMPUTER TEACHING
11.1.3	LED		
12.1.0	DIM800		
12.1.1	Input 1	27	PSYCHOLOGY
12.1.2	Input 2	28	ARCHITECTURE BUILDINGS
12.1.3	LED		
13.1.0	DIM800		
13.1.1	Input 1	29	ARCHITECTURAL DRAWING STUDIO
13.1.2	Input 2	30	ARCHITECTURAL B E WORKSHOP
13.1.3	LED		
14.1.0	DIM800		
14.1.1	Input 1	32	ENGINEERING "A"
14.1.2	Input 2	33	ENGINEERING "B"
14.1.3	LED		
15.1.0	DIM800		
15.1.1	Input 1	34	ENGINEERING "C"
15.1.2	Input 2	35	ENGINEERING "D"
15.1.3	LED		
16.1.0	DIM800		
16.1.1	Input 1	36	ENGINEERING "E"

ADDR.	Type	Zone	Description
16.1.2	Input 2	37	ENGINEERING "F"
16.1.3	LED		
17.1.0	DIM800		
17.1.1	Input 1	38	ENGINEERING "G"
17.1.2	Input 2	39	ENGINEERING "S"
17.1.3	LED		
18.1.0	DIM800		
18.1.1	Input 1	40	TUNRA ANNEX BUILDING
18.1.2	Input 2	41	CHANCELLERY
18.1.3	LED		
19.1.0	DIM800		
19.1.1	Input 1	42	ATC BUILDING
19.1.2	Input 2	43	CENTRAL ANIMAL HOUSE BUILDINGS
19.1.3	LED		
20.1.0	DIM800		
20.1.1	Input 1	44	HEALTH & PHYSICAL EDUCATION
20.1.2	Input 2	45	THE FORUM
20.1.3	LED		
21.1.0	DIM800		
21.1.1	Input 1	46	NURSING BUILDING
21.1.2	Input 2	47	ACADEMIC OFFICE BLOCK
21.1.3	LED		
22.1.0	DIM800		
22.1.1	Input 1	48	HUNTER
22.1.2	Input 2	49	STUDENT SERVICES CENTRE
22.1.3	LED		
23.1.0	DIM800		
23.1.1	Input 1	50	NUSA BUILDING 'K-18'
23.1.2	Input 2	51	HUNTER UNION
23.1.3	LED		
24.1.0	DIM800		
24.1.1	Input 1	52	SPECIAL ED./EAST CAMPUS SW/RM

ADDR.	Type	Zone	Description
24.1.2	Input 2	53	VAMS BUILDING
24.1.3	LED		
25.1.0	DIM800		
25.1.1	Input 1	54	GALLERY OF FINE ARTS
25.1.2	Input 2	55	DESIGN
25.1.3	LED		
26.1.0	DIM800		
26.1.1	Input 1	56	BIRABAHN
26.1.2	Input 2	57	SERVICES BUILDING
26.1.3	LED		
27.1.0	DIM800		
27.1.1	Input 1	58	STUDENT ACCOMMODATION WEST
27.1.2	Input 2 Not Used		
27.1.3	LED		
28.1.0	DIM800		
28.1.1	Input 1	60	STUDENT ACCOMMODATION NORTH
28.1.2	Input 2 Not Used		
28.1.3	LED		
29.1.0	DIM800		
29.1.1	Input 1	62	STUDENT ACCOMMODATION EAST
29.1.2	Input 2 Not Used		
29.1.3	LED		
30.1.0	DIM800		
30.1.1	Input 1	64	STUDENT ACCOMMODATION SOUTH
30.1.2	Input 2 Not Used		
30.1.3	LED		
31.1.0	DIM800		
31.1.1	Input 1	66	ACCOMMODATION HUB EVATT HOUSE
31.1.2	Input 2	67	EVATT HOUSE COMMON ROOM
31.1.3	LED		
32.1.0	DIM800		
32.1.1	Input 1	68	EVATT HOUSE BLOCK "A"

ADDR.	Type	Zone	Description
32.1.2	Input 2	69	EVATT HOUSE BLOCK "B"
32.1.3	LED		
33.1.0	DIM800		
33.1.1	Input 1	70	EVATT HOUSE BLOCK "C"
33.1.2	Input 2	71	EVATT HOUSE BLOCK "D"
33.1.3	LED		
34.1.0	DIM800		
34.1.1	Input 1	72	EVATT HOUSE BLOCK "E"
34.1.2	Input 2	73	EVATT HOUSE BLOCK "F"
34.1.3	LED		
35.1.0	DIM800		
35.1.1	Input 1	74	EVATT HOUSE BLOCK "G"
35.1.2	Input 2	75	EVATT HOUSE BLOCK "H"
35.1.3	LED		
36.1.0	DIM800		
36.1.1	Input 1	76	EVATT HOUSE BLOCK "J"
36.1.2	Input 2	77	EVATT HOUSE BLOCK "K"
36.1.3	LED		
37.1.0	DIM800		
37.1.1	Input 1	78	INTERNATIONAL HOUSE BLOCK 1
37.1.2	Input 2	79	INTERNATIONAL HOUSE BLOCK 2
37.1.3	LED		
38.1.0	DIM800		
38.1.1	Input 1	80	INTERNATIONAL HOUSE BLOCK 3
38.1.2	Input 2	81	INTERNATIONAL HOUSE BLOCK 4
38.1.3	LED		
39.1.0	DIM800		
39.1.1	Input 1	82	INTERNATIONAL HOUSE BLOCK 5
39.1.2	Input 2	83	INTERNATIONAL HOUSE BLOCK 6
39.1.3	LED		
40.1.0	DIM800		
40.1.1	Input 1	84	INTERNATIONAL HOUSE BLOCK 7

ADDR.	Type	Zone	Description
40.1.2	Input 2	85	INTERNATIONAL HOUSE BLOCK 8
40.1.3	LED		
41.1.0	DIM800		
41.1.1	Input 1	86	INTERNATIONAL HOUSE BLOCK 9
41.1.2	Input 2	87	INTERNATIONAL HOUSE BLOCK 10
41.1.3	LED		
42.1.0	DIM800		
42.1.1	Input 1	88	INTERNATIONAL HOUSE BLOCK 11
42.1.2	Input 2	89	INTERNATIONAL HOUSE BLOCK 12
42.1.3	LED		
43.1.0	DIM800		
43.1.1	Input 1	90	INTERNATIONAL HOUSE COMMON RM
43.1.2	Input 2	91	EDWARD'S HALL
43.1.3	LED		
44.1.0	DIM800		
44.1.1	Input 1	92	BARAHINEBAN
44.1.2	Input 2	93	KOOINDA CHILD CARE CENTRE
44.1.3	LED		
45.1.0	DIM800		
45.1.1	Input 1	94	IDC BUILDING
45.1.2	Input 2 Not Used		
45.1.3	LED		
46.1.0	DIM800		
46.1.1	Input 1 Not Used		
46.1.2	Input 2 Not Used		
46.1.3	LED		



**ATTACHMENT 4**

**MX1 PHONE LINE CONNECTIONS**

CABLE 1	CORE	PAIR	ZONE	ZONE DESCRIPTION	CORE
BLUE WRAP	WHITE	1	1	PUMP ROOM SITE MAIN FIP	NOT USED
	BLUE				
	WHITE	2	2	SUB ZERO	NOT USED
	ORANGE				
	WHITE	3	3	ICT BUILDING	1
	GREEN				
	WHITE	4	4	GREAT HALL	2
	BROWN				
	WHITE	5	5	EARTH SCIENCE	3
	SLATE				
RED	6	6	SCIENCE LECTURE THEATRE	4	
BLUE					
RED	7	7	PHYSICS	5	
ORANGE					
RED	8	8	CHEMISTRY & SCIENCE	6	
GREEN					
RED	9	9	BASDEN LECTURE THEATRE	7	
BROWN					
RED	10	10	LIFE SCIENCE THATRE	8	
SLATE					
ORANGE WRAP	WHITE	11	11	BIOLOGICAL SCIENCES	9
	BLUE				
	WHITE	12	12	NEW BIO RESOURCE	NOT USED
	ORANGE				
	WHITE	13	13	MEDICAL SCIENCE WEST	10
	GREEN				
	WHITE	14	14	MEDICAL SCIENCES	11
	BROWN				
	WHITE	15	15	LIFE SCIENCES	12
	SLATE				
RED	16	16	AUCHMUTY LIBRARY	13	
BLUE					
RED	17	17	LANGUAGE CENTRE	14	
ORANGE					
RED	18	18	SHORTLAND UNION BUILDING	15	
GREEN					
RED	19	19	GENERAL PURPOSE BUILDING	16	
BROWN					
RED	20	20	SOCIAL SCIENCES	17	
SLATE					
GREEN WRAP	WHITE	21	21	DRAMA STUDIO	18
	BLUE				
	WHITE	22	22	DRAMA BUILDING	19
	ORANGE				
	WHITE	23	23	STEM ENABLING (McMULLIN)	NOT USED
	GREEN				
	WHITE	24	24	BEHAVIOURAL SCIENCES	20
	BROWN				
	WHITE	25	25	MATHEMATICS	21
	SLATE				
RED	26	26	COMPUTER TEACHING	22	
BLUE					
RED	27	27	PSYCHOLOGY	23	
ORANGE					
RED	28	28	ARCHITECTURE BUILDINGS	24	
GREEN					
RED	29	29	ARCHITECTURAL DRAWING STUDIO	25	
BROWN					
RED	30	30	ARCHITECTURE B E WORKSHOP	26	
SLATE					

CABLE 1	CORE	PAIR	ZONE	ZONE DESCRIPTION	CORE
BROWN WRAP	WHITE	31	31	NIER BLD (SIGNAL ONLY)	NOT USED
	BLUE				
	WHITE	32	32	ENGINEERING "A"	27
	ORANGE				
	WHITE	33	33	ENGINEERING "B"	28
	GREEN				
	WHITE	34	34	ENGINEERING "C"	29
	BROWN				
	WHITE	35	35	ENGINEERING "D"	30
	SLATE				
	RED	36	36	ENGINEERING "E"	31
	BLUE				
	RED	37	37	ENGINEERING "F"	32
	ORANGE				
	RED	38	38	ENGINEERING "G"	33
	GREEN				
RED	39	39	ENGINEERING "S"	34	
BROWN					
RED	40	40	TUNRA ANNEXE BUILDING	35	
SLATE					
SLATE WRAP	WHITE	41	41	CHANCELLERY	36
	BLUE				
	WHITE	42	42	ATC BUILDING	37
	ORANGE				
	WHITE	43	43	CENTRAL ANIMAL HOUSE BUILDINGS	38
	GREEN				
	WHITE	44	44	HEALTH & PHYSICAL EDUCATION	39
	BROWN				
	WHITE	45	45	THE FORUM	40
	SLATE				
	RED	46	46	NURSING BUILDING	41
	BLUE				
	RED	47	47	ACADEMIC OFFICE BLOCK	42
	ORANGE				
	RED	48	48	HUNTER	43
	GREEN				
RED	49	49	STUDENT SERVICES CENTRE	44	
BROWN					
RED	50	50	NUSA BUILDING 'K-18'	45	
SLATE					

CABLE 2	CORE	PAIR	ZONE	ZONE DESCRIPTION	CORE
BLUE WRAP	WHITE	1	51	HUNTER UNION	46
	BLUE				
	WHITE	2	52	SPECIAL ED./EAST CAMPUS SW/RM	47
	ORANGE				
	WHITE	3	53	VAMS BUILDING	48
	GREEN				
	WHITE	4	54	GALLERY OF FINE ARTS	49
	BROWN				
	WHITE	5	55	DESIGN	50
	SLATE				
	RED	6	56	BIRABAHN	51
	BLUE				
	RED	7	57	SERVICES BUILDING	52
	ORANGE				
	RED	8	58	STUDENT ACCOMMODATION WEST	53
	GREEN				
RED	9	59	SPARE	NOT USED	
BROWN					
RED	10	60	STUDENT ACCOMMODATION NORTH	54	
SLATE					

CABLE 2	CORE	PAIR	ZONE	ZONE DESCRIPTION	CORE
ORANGE WRAP	WHITE	11	61	SPARE	NOT USED
	BLUE				
	WHITE	12	62	STUDENT ACCOMMODATION EAST	55
	ORANGE				
	WHITE	13	63	SPARE	NOT USED
	GREEN				
	WHITE	14	64	STUDENT ACCOMMODATION SOUTH	56
	BROWN				
	WHITE	15	65	SPARE	NOT USED
	SLATE				
	RED	16	66	ACCOMMODATION HUB	57
	BLUE				
	RED	17	67	EVATT HOUSE COMMON ROOM	58
	ORANGE				
RED	18	68	EVATT HOUSE BLOCK "A"	59	
GREEN					
RED	19	69	EVATT HOUSE BLOCK "B"	60	
BROWN					
RED	20	70	EVATT HOUSE BLOCK "C"	61	
SLATE					
GREEN WRAP	WHITE	21	71	EVATT HOUSE BLOCK "D"	62
	BLUE				
	WHITE	22	72	EVATT HOUSE BLOCK "E"	63
	ORANGE				
	WHITE	23	73	EVATT HOUSE BLOCK "F"	64
	GREEN				
	WHITE	24	74	EVATT HOUSE BLOCK "G"	65
	BROWN				
	WHITE	25	75	EVATT HOUSE BLOCK "H"	66
	SLATE				
	RED	26	76	EVATT HOUSE BLOCK "J"	67
	BLUE				
	RED	27	77	EVATT HOUSE BLOCK "K"	68
	ORANGE				
RED	28	78	INTERNATIONAL HOUSE BLOCK 1	69	
GREEN					
RED	29	79	INTERNATIONAL HOUSE BLOCK 2	70	
BROWN					
RED	30	80	INTERNATIONAL HOUSE BLOCK 3	71	
SLATE					
BROWN WRAP	WHITE	31	81	INTERNATIONAL HOUSE BLOCK 4	72
	BLUE				
	WHITE	32	82	INTERNATIONAL HOUSE BLOCK 5	73
	ORANGE				
	WHITE	33	83	INTERNATIONAL HOUSE BLOCK 6	74
	GREEN				
	WHITE	34	84	INTERNATIONAL HOUSE BLOCK 7	75
	BROWN				
	WHITE	35	85	INTERNATIONAL HOUSE BLOCK 8	76
	SLATE				
	RED	36	86	INTERNATIONAL HOUSE BLOCK 9	77
	BLUE				
	RED	37	87	INTERNATIONAL HOUSE BLOCK 10	78
	ORANGE				
RED	38	88	INTERNATIONAL HOUSE BLOCK 11	79	
GREEN					
RED	39	89	INTERNATIONAL HOUSE BLOCK 12	80	
BROWN					
RED	40	90	INTERNATIONAL HOUSE COMMON RM	81	
SLATE					

CABLE 2	CORE	PAIR	ZONE	ZONE DESCRIPTION	CORE
SLATE WRAP	WHITE	41	91	EDWARD'S HALL	82
	BLUE				
	WHITE	42	92	BARAHINEBAN	83
	ORANGE				
	WHITE	43	93	KOOINDA CHILD CARE CENTRE	84
	GREEN				
	WHITE	44	94	IDC BUILDING	85
	BROWN				
	WHITE	45	95	McMULLIN THEATRE	86
	SLATE				
	RED	46	96	McMULLIN	87
	BLUE				
	RED	47	97		NOT USED
	ORANGE				
	RED	48	98		NOT USED
GREEN					
RED	49	99		NOT USED	
BROWN					
RED	50	100		NOT USED	
SLATE					

CABLE 3	CORE	PAIR	ZONE	ZONE DESCRIPTION	CORE
BLUE WRAP	WHITE	1		FIP 1 BRIGADE ENTRY POINT	
	BLUE				
	WHITE	2		FIP 1 BRIGADE ENTRY POINT	
	ORANGE				
	WHITE	3		FIP 1 BRIGADE ENTRY POINT	
	GREEN				
	WHITE	4		FIP 2 BRIGADE ENTRY POINT	
	BROWN				
	WHITE	5		FIP 2 BRIGADE ENTRY POINT	
	SLATE				
RED	6		FIP 2 BRIGADE ENTRY POINT		
BLUE					

**ATTACHMENT 5      PSEUDO POINTS**

Pseudo Point	Zone	Description
242.2	1	PUMP ROOM SITE MAIN FIP
242.3	2	SUB ZERO
242.4	3	ICT BUILDING
242.5	4	GREAT HALL
242.6	5	EARTH SCIENCE
242.7	6	SCIENCE LECTURE THEARE
242.8	7	PHYSICS
242.9	8	CHEMISTRY & SCIENCE
242.10	9	BASDEN LECTURE THEATRE
242.11	10	LIFE SCIENCE THEATRE
242.12	11	BIOLOGICAL SCIENCES
242.13	12	BIORESOURCE FACILITY
242.14	13	MEDICAL SCIENCE WEST
242.15	14	MEDICAL SCIENCES
242.16	15	LIFE SCIENCES
242.17	16	AUCHMUTY LIBRARY
242.18	17	LANGUAGE CENTRE
242.19	18	SHORTLAND UNION BUILDING
242.20	19	GENERAL PURPOSE BUILDING
242.21	20	SOCIAL SCIENCES
242.22	21	DRAMA STUDIO
242.23	22	DRAMA BUILDING
242.24	23	STEM ENABLING
242.25	24	BEHAVIOURAL SCIENCES
242.26	25	MATHEMATICS
242.27	26	COMPUTER TEACHING
242.28	27	PSYCHOLOGY
242.29	28	ARCHITECTURE BUILDINGS
242.30	29	ARCHITECTURAL DRAWING STUDIO
242.31	30	ARCHITECTURE B E WORKSHOP
242.32	31	NIER BLD (SIGNAL ONLY)
242.33	32	ENGINEERING "A"
242.34	33	ENGINEERING "B"
242.35	34	ENGINEERING "C"
242.36	35	ENGINEERING "D"
242.37	36	ENGINEERING "E"
242.38	37	ENGINEERING "F"
242.39	38	ENGINEERING "G"
242.40	39	ENGINEERING "S"
242.41	40	TUNRA ANNEXE BUILDING
242.42	41	CHANCELLERY
242.43	42	ATC BUILDING
242.44	43	CENTRAL ANIMAL HOUSE BUILDINGS
242.45	44	HEATH & PHYSICAL EDUCATION

Pseudo Point	Zone	Description
242.46	45	THE FORUM
242.47	46	NURSING BUILDING
242.48	47	ACADEMIC OFFICE BLOCK
242.49	48	HUNTER
242.50	49	STUDENT SERVICES CENTRE
242.51	50	NUSA BUILDING 'K-18'
242.52	51	HUNTER UNION
242.53	52	SPECIAL ED./EAST CAMPUS SW/RM
242.54	53	VAMS BUILDING
242.55	54	GALLERY OF FINE ARTS
242.56	55	DESIGN
242.57	56	BIRABAHN
242.58	57	SERVICES BUILDING
242.59	58	STUDENT ACCOMMODATION WEST
242.60	59	SPARE
242.61	60	STUDENT ACCOMMODATION NORTH
242.62	61	SPARE
242.63	62	STUDENT ACCOMMODATION EAST
242.64	63	SPARE
242.65	64	STUDENT ACCOMMODATION SOUTH
242.66	65	SPARE
242.67	66	ACCOMMODATION HUB
242.68	67	EVATT HOUSE COMMON ROOM
242.69	68	EVATT HOUSE BLOCK "A"
242.70	69	EVATT HOUSE BLOCK "B"
242.71	70	EVATT HOUSE BLOCK "C"
242.72	71	EVATT HOUSE BLOCK "D"
242.73	72	EVATT HOUSE BLOCK "E"
242.74	73	EVATT HOUSE BLOCK "F"
242.75	74	EVATT HOUSE BLOCK "G"
242.76	75	EVATT HOUSE BLOCK "H"
242.77	76	EVATT HOUSE BLOCK "J"
242.78	77	EVATT HOUSE BLOCK "K"
242.79	78	INTERNATIONAL HOUSE BLOCK 1
242.80	79	INTERNATIONAL HOUSE BLOCK 2
242.81	80	INTERNATIONAL HOUSE BLOCK 3
242.82	81	INTERNATIONAL HOUSE BLOCK 4
242.83	82	INTERNATIONAL HOUSE BLOCK 5
242.84	83	INTERNATIONAL HOUSE BLOCK 6
242.85	84	INTERNATIONAL HOUSE BLOCK 7
242.86	85	INTERNATIONAL HOUSE BLOCK 8
242.87	86	INTERNATIONAL HOUSE BLOCK 9
242.88	87	INTERNATIONAL HOUSE BLOCK 10
242.89	88	INTERNATIONAL HOUSE BLOCK 11
242.90	89	INTERNATIONAL HOUSE BLOCK 12

Pseudo Point	Zone	Description
242.91	90	INTERNATIONAL HOUSE COMMON ROOM
242.92	91	EDWARD'S HALL
242.93	92	BARAHINEBAN
242.94	93	KOOINDA CHILD CARE CENTRE
242.95	94	IDC BUILDING
242.96	95	CERAMICS
242.97	96	COMMONWEALTH BANK
242.98		
242.99		
242.100		
242.101		
242.102		
242.103		
242.104		
242.105		
242.106		
242.107	106	Q BUILDING
242.108	107	OURIMBAH CAMPUS
242.109	108	CONSERVATORIUM OF MUSIC
242.110	109	NU SPACE
242.111	110	UNIVERSITY HOUSE
242.112	111	NORTHUMBERLAND HOUSE

**ATTACHMENT 6 THE VOIP NETWORK (PROPOSED)**

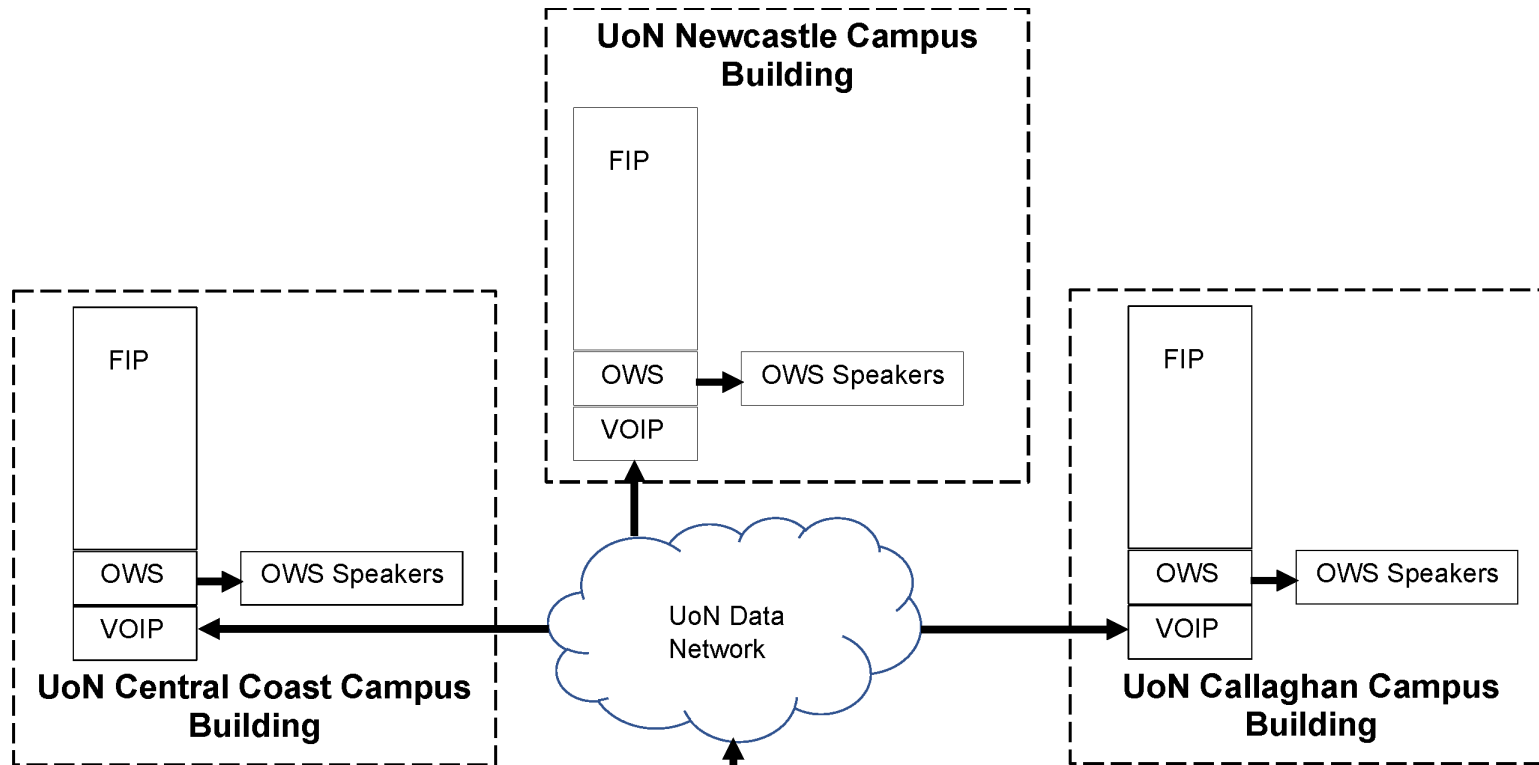

**UoN Emergency Evacuation System Concept**

The system is intended to provide UoN emergency control person the ability to manage emergency situations on local or remote campus from a central location.

Emergency personnel will be able directly address individual buildings, groups of buildings or an entire campus using voice instructions or pre-recorded emergency evacuation instructions.

The system will utilise the UoN data network

**Legend**

**FIP** – Fire indication panel (existing)

**OWS** – Occupant Warning system tone generator (existing in some buildings, new in others)

**OWS Speakers** – dedicated OWS speakers connected to the OWS tone generator. (existing in some buildings, new in others)

**VOIP** – Voice Over Internet Protocol. An interface which allows voice transmission over the UoN data network from the emergency control panel to the OWS tone generator (existing in some buildings, new in others)



# TYPICAL BUILDING NETWORK CONNECTIONS

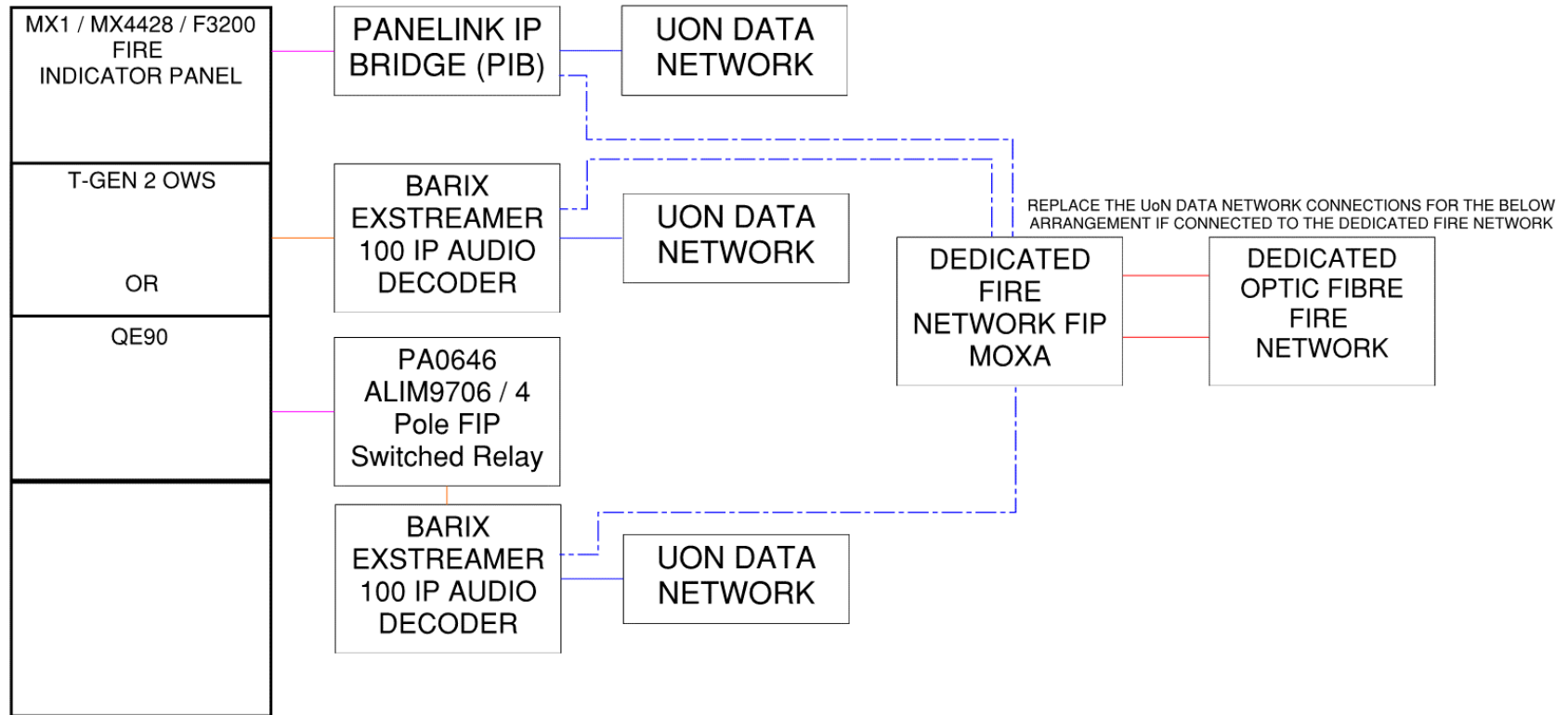

**ATTACHMENT 8 FIRE DETECTION SYSTEM MATRIX**

SITE NAME:		MSW MEDICAL SCIENCE WEST		(Zone Config "L" = Latching; "N" = Non Latching)											
Fire Panel Cause and Affect															
FIP Inputs				FIP Outputs											
Zone		Description	Zone Config	MAF	FLT	ISO	EBO	WSO	A0	A401	A500	A501	A502	A503	A504
1	A	L2 ENTRY	L	✓			✓	✓	✓	✓	✓	✓	✓	✓	✓
	F			✓											
	I														
2	A	L2 LAB SOUTH & PREP ROOMS	L	✓			✓	✓	✓	✓	✓	✓	✓	✓	✓
	F			✓											
	I														
3	A	L2 LAB NORTH	L	✓			✓	✓	✓	✓	✓	✓	✓	✓	✓
	F			✓											
	I														
4	A	L1 BIO PHARMACY LAB	L	✓			✓	✓	✓	✓	✓	✓	✓	✓	✓
	F			✓											
	I														
5	A	L1 HEARSE RECEIPT AREA & SWITCH	L	✓			✓	✓	✓	✓	✓	✓	✓	✓	✓
	F			✓											
	I														

**UNIVERSITY OF NEWCASTLE**

SITE NAME: **MSW MEDICAL SCIENCE WEST**

(Zone Config "L" = Latching; "N" = Non Latching)

Fire Panel Cause and Affect

FIP Inputs				FIP Outputs											
Zone		Description	Zone Config	MAF	FLT	ISO	EBO	WSO	A0	A401	A500	A501	A502	A503	A504
6	A	L1 UNDERCROFT	L	✓			✓	✓	✓	✓	✓	✓	✓	✓	✓
	F			✓											
	I														
7	A	L3 ENTRY	L	✓			✓	✓	✓	✓	✓	✓	✓	✓	✓
	F			✓											
	I														
8	A	L3 NORTH ANATOMY	L	✓			✓	✓	✓	✓	✓	✓	✓	✓	✓
	F			✓											
	I														
9	A	L3 SOUTH DISSECTION	L	✓			✓	✓	✓	✓	✓	✓	✓	✓	✓
	F			✓											
	I														
10	A	L4 PLANTROOM No.2	L	✓			✓	✓	✓	✓	✓	✓	✓	✓	✓
	F			✓											
	I														
11	A	L4 ENTRY	L	✓			✓	✓	✓	✓	✓	✓	✓	✓	✓

**UNIVERSITY OF NEWCASTLE**

SITE NAME: **MSW MEDICAL SCIENCE WEST**

(Zone Config "L" = Latching; "N" = Non Latching)

Fire Panel Cause and Affect

FIP Inputs				FIP Outputs											
Zone		Description	Zone Config	MAF	FLT	ISO	EBO	WSO	A0	A401	A500	A501	A502	A503	A504
	F				✓										
	I														
12	A	L4 RESOURCES AREA	L	✓			✓	✓	✓	✓	✓	✓	✓	✓	✓
	F			✓											
	I														
13	A	L4 PLANTROOM No.1	L	✓			✓	✓	✓	✓	✓	✓	✓	✓	✓
	F			✓											
	I														
14	A	L4 EMBALMING	L	✓			✓	✓	✓	✓	✓	✓	✓	✓	✓
	F			✓											
	I														
15	A	L5 LEVEL 5	L	✓			✓	✓	✓	✓	✓	✓	✓	✓	✓
	F			✓											
	I														
16	A	L6 PLANTROOM No.3	L	✓			✓	✓	✓	✓	✓	✓	✓	✓	✓
	F			✓											
	I														

**UNIVERSITY OF NEWCASTLE**

SITE NAME: **MSW MEDICAL SCIENCE WEST**

(Zone Config "L" = Latching; "N" = Non Latching)

Fire Panel Cause and Affect

FIP Inputs				FIP Outputs											
Zone		Description	Zone Config	MAF	FLT	ISO	EBO	WSO	A0	A401	A500	A501	A502	A503	A504
17	A	L6 LIFT SHAFT	L	✓			✓	✓	✓	✓	✓	✓	✓	✓	✓
	F			✓											
	I														
18	A	L6 BIO PHARMACY FUME FC-1-01 D	L	✓			✓	✓	✓	✓	✓	✓	✓	✓	✓
	F			✓											
	I														
19	A	L6 LAB NORTH FUME FC-2-01 DUCT	L	✓			✓	✓	✓	✓	✓	✓	✓	✓	✓
	F			✓											
	I														
20	A	L6 LAB NORTH FUME FC-2-02 DUCT	L	✓			✓	✓	✓	✓	✓	✓	✓	✓	✓
	F			✓											
	I														
21	A	L6 PREP ROOM FUME FC-2-05 DUCT	L	✓			✓	✓	✓	✓	✓	✓	✓	✓	✓
	F			✓											
	I														
22	A		L	✓			✓	✓	✓	✓	✓	✓	✓	✓	✓

**UNIVERSITY OF NEWCASTLE**

SITE NAME: **MSW MEDICAL SCIENCE WEST**

(Zone Config "L" = Latching; "N" = Non Latching)

Fire Panel Cause and Affect

FIP Inputs				FIP Outputs											
Zone		Description	Zone Config	MAF	FLT	ISO	EBO	WSO	A0	A401	A500	A501	A502	A503	A504
	F	L6 LAB SOUTH FUME FC-2-04 DUCT			✓										
	I														
23	A	L6 LAB SOUTH FUME FC-2-03 DUCT	L	✓			✓	✓	✓	✓	✓	✓	✓	✓	✓
	F			✓											
	I														
24	A	L6 EMBALMING FUME EAF-EC-4-1 D	L	✓			✓	✓	✓	✓	✓	✓	✓	✓	✓
	F			✓											
	I														
Zone		Description	Zone Config	MAF	FLT	ISO	EBO	WSO	A0	A401	A500	A501	A502	A503	A504
				Repeats to Main FIP	Repeats to Main FIP		A501 MAPPED	A401 MAPPED	A501, 502, 503 & 504 MAPPED	EWIS TRIGGER	A/C TRIP	EXTERNAL STROBE	STROBE	SECURITY TRIP	AUTOMATIC DOOR TRIP

## ATTACHMENT 9 SMALL FIBRE ENCLOSURES

Fibre Enclosures and Racks



### Small Wall/DIN Rail Mounted Enclosure

The Small Wall/DIN Rail Mounted Enclosure accepts one modular panel making it ideal for smaller fibre count applications of up to 24 fibres.

This compact enclosure makes it possible to direct terminate or fusion splice in much smaller protected areas. Its professional appearance is well suited for any office, corporate or industrial installation.

#### Features

- Small size making it very versatile
- Modular front design to suit one AFL flat or angled panel for various connector types and densities
- Standard metal lid included, optional clear Perspex cover available for highlighting unauthorised access or tampering
- Top, bottom and side cable entry to suit various installation requirements
- Able to accommodate MTP loaded cassette or bracket
- Mounting options include wall mounting or DIN rail mounting
- Standard accessories include cable gland, management clips, strain relief post and DIN or wall mounting brackets
- Loaded enclosures available

#### Applications

- Suitable for direct termination and fusion splicing of loose tube and tight buffer cables
- Remote cable terminations within building
- Quick connection using an MTP cassette or pre-terminated cabling solution
- Inside cabinets using DIN rail mounting clip
- Defence requirements for identifying tampering or accidental fibre disconnections



Australia: 1300 232 476 New Zealand: 09 927 7140  
www.AFLglobal.com

© 2000-2020, AFL, all rights reserved. 0180, Revision 7, 30.11.20  
Specifications are subject to change without notice.

## Small Wall/DIN Rail Mounted Enclosure

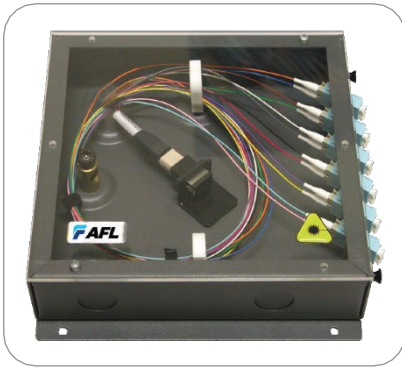

Pre-terminated MTP to LC solution

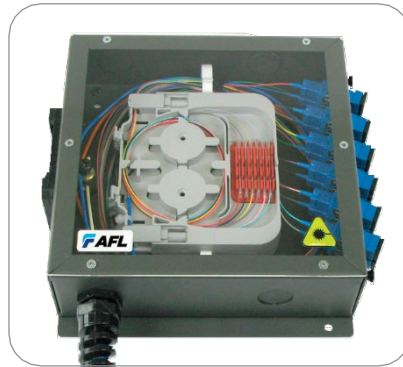

Fusion splicing multi-coloured pigtails onto loose tube cable



Direct termination onto riser cable

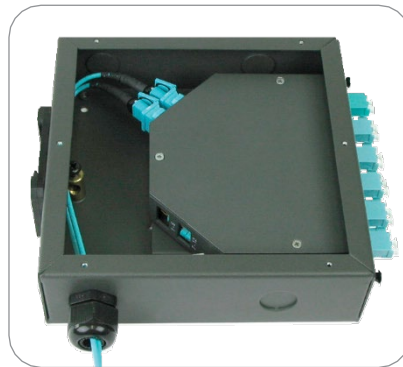

Loaded with 24 fibre MTP-LC cassette (special gland required for this option (CABGN20))

## Technical Specifications

Part Number	FWE-MOD-SM
Description	1 Panel Modular Small Wall Enclosure
Dimensions (w) x (d) x (h) excluding mounting brackets	180 mm x 54 mm x 180 mm
Weight unloaded excl. accessories and packaging	1.3 kg
Quantity of modular panels	1
Maximum fibre count	24F LC
Cable entry	2 top and 2 bottom, 2 side, maximum 6 cables
Material and colour	1.6 mm mild steel, powder coated charcoal grey
Accessory kit	Standard accessories included with each enclosure: metal lid, cable strength member anchor, 2 cable management clips, 20 mm cable gland, cassette mounting bracket, wall mounting brackets and DIN clip

Australia: 1300 232 476 New Zealand: 09 927 7140  
[www.AFLglobal.com](http://www.AFLglobal.com)

© 2002-2020, AFL, all rights reserved. 0180, Revision 7, 30.11.20  
 Specifications are subject to change without notice.



## Small Wall/DIN Rail Mounted Enclosure

### Ordering Information



Clip-in Metal Coupler Panels, Screen-printed		
FRE-BLANK	Blank Panel	
FRE-SC06H-FL1/6	SC/LCD 6P Panel 1-6HP Flat	
FRE-SC06H-AL1/6	SC/LCD 6P Panel 1-6HP Angle left	
FRE-SC06H-AR1/6	SC/LCD 6P Panel 1-6HP Angle right	
FRE-SC12D-FL1/12	SC/LCD 12P Panel 1-12DP Flat	
FRE-SC12D-FL13/24	SC/LCD 12P Panel 13-24DP Flat	
FRE-SC12H-AL1/12	SC/LCD 12P Panel 1-12HP Angle left	
FRE-SC12H-AR1/12	SC/LCD 12P Panel 1-12HP Angle right	
FRE-SC12V-AL1/12	SC/LCD 12P Panel 1-12VP Angle left	
FRE-SC12V-AR13/24	SC/LCD 12P Panel 13-24VP Angle right	
FRE-SCD03H-FL1/6	SC Duplex 3P Panel 1-6HP Flat	
FRE-SCD03H-AL1/6 SC	Duplex 3P Panel 1-6HP Angle left	
FRE-SCD03H-AR1/6 SC	Duplex 3P Panel 1-6HP Angle right	
FRE-SCD06D-FL1/12	SC Duplex 6P Panel 1-12DP Flat	
FRE-SCD06H-AL1/12	SC Duplex 6P Panel 1-12HP Angle left	
FRE-SCD06H-AR1/12	SC Duplex 6P Panel 1-12HP Angle right	
FRE-ST06H-FL1/6	ST/FC 6P Panel 1-6HP Flat	
FRE-ST06H-AL1/6	ST/FC 6P Panel 1-6HP Angle left	
FRE-ST06H-AR1/6	ST/FC 6P Panel 1-6HP Angle right	
FRE-ST12D-FL1/12	ST/FC 12P Panel 1-12DP Flat	
FRE-ST12D-FL13/24	ST/FC 12P Panel 13-24DP Flat	

**Australia: 1300 232 476 New Zealand: 09 927 7140**  
**www.AFLglobal.com**

© 2002-2020, AFL, all rights reserved. 0180, Revision 7, 30.11.20  
 Specifications are subject to change without notice.

## Small Wall/DIN Rail Mounted Enclosure

### Optional Additional Accessories

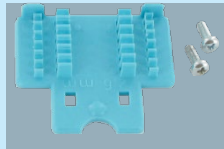
PART NUMBER	DESCRIPTION	
FWE-MOD-SM-CLPP	Clear Perspex cover with mounting screws	
SPLCASS-SSH-HD-6/12K SPLCASS-SSH-HD-12/24K	12/24 fibre mini splice cassette with hinged cover, mounting screws and splice protectors	
SPLCOMB-HDHS-BU	12 fibre high density splice comb with mounting screws	

Full range of additional accessories available including:

- Pigtails
- Simplex and duplex adapters
- Pre-terminated MTP cabling solution
- Splicing consumables
- Termination consumables

### Loaded Enclosures

AFL can supply this wall enclosure as a kit with any of the options mentioned above.

Shown right, is an example of a MOD-SM enclosure which has been loaded with 2 splice cassettes, pigtails, adapter panel with adapters, clear cover and DIN rail clip.

The AFL part number for this product is: WO-1CH-BP-

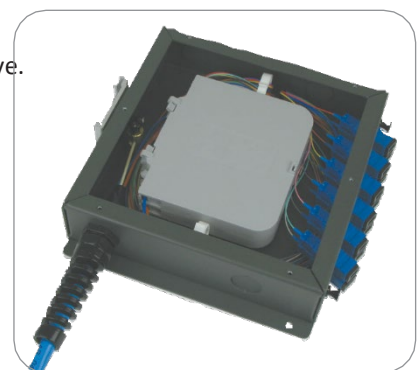

**Australia: 1300 232 476 New Zealand: 09 927 7140**  
**www.AFLglobal.com**

© 2002-2020, AFL, all rights reserved. 0180, Revision 7, 30.11.20  
 Specifications are subject to change without notice.



**Modular DIN Rail Mounted Enclosure**



The Modular DIN Rail Mounted Enclosure is specifically designed for applications where space is at a premium. It has all the advantages and functionality of larger enclosures, but with a smaller footprint. Front and side patching makes it suitable for a large range of operating environments.

Suitable for fusion splicing or direct termination, it has provisions for splice cassettes, modular adapter panels and AFL’s MTP cassette solution.

**Features**

- Modular external apertures to suit AFL flat or angled panels for various connector types and densities
- Side panels can accommodate AFL’s Modular MTP cassettes
- Lockable splicing compartment for restricted entry
- Internal fibre clips for managing incoming cables and fibre pigtails
- Top, bottom and LHS cable entry points for ceiling or floor access
- Option of front or side patching on RHS with patch plates for both included
- Side and rear DIN rail mountable for easy and fast installations

**Applications**

- Remote cable locations, e.g. communication rooms, warehouses, campuses, high rise buildings
- Industrial automation environments
- Multimedia applications using fibre and copper cabling, e.g. mining camps
- Data centres and SAN environments requiring MTP or pre-terminated cabling solutions
- Suitable for use as a Multi-user Telecommunications Outlet (MUTO)



FWE-MOD-12-M-C loaded with MTP-LC cassettes



FWE-MOD-12-M-C side mounted to DIN rail

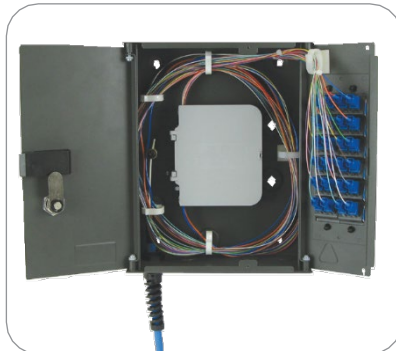

FWE-MOD-12-M-C loaded with two splice cassettes and pigtails mounted in the termination compartment



FWE-MOD-12-M-C rear mounted to DIN rail

## Technical Specifications

Part Number	FWE-MOD-12-M-C
Description	2 panel compact modular wall enclosure
Dimensions (mm) (w) x (d) x (h)	205 x 80 x 250
Weight (kg)	1.9
Maximum modular external panels or MTP cassettes	2
Maximum fibre count	24 ST, SC, FC & 48 LC
Maximum incoming cable ports	Top – 4 x 20 mm, Bottom – 4 x 20 mm, LHS – 4 x 20 mm
Material and colour	1.2 mm mild steel, powder coated grey

## Modular DIN Rail Mounted Enclosure

### Ordering Information

PANELS		
FRE-BLANK	Blank Panel	
FRE-SC06H-FL1/6	SC/LCD 6P Panel 1-6HP Flat	
FRE-SC06H-AL1/6	SC/LCD 6P Panel 1-6HP Angle left	
FRE-SC06H-AR1/6	SC/LCD 6P Panel 1-6HP Angle right	
FRE-SC12D-FL1/12	SC/LCD 12P Panel 1-12DP Flat	
FRE-SC12D-FL13/24	SC/LCD 12P Panel 13-24DP Flat	
FRE-SC12H-AL1/12	SC/LCD 12P Panel 1-12HP Angle left	
FRE-SC12H-AR1/12	SC/LCD 12P Panel 1-12HP Angle right	
FRE-SC12V-AL1/12	SC/LCD 12P Panel 1-12VP Angle left	
FRE-SC12V-AR13/24	SC/LCD 12P Panel 13-24VP Angle right	
FRE-SCD03H-FL1/6	SC Duplex 3P Panel 1-6HP Flat	
FRE-SCD03H-AL1/6 SC	Duplex 3P Panel 1-6HP Angle left	
FRE-SCD03H-AR1/6 SC	Duplex 3P Panel 1-6HP Angle right	
FRE-SCD06D-FL1/12	SC Duplex 6P Panel 1-12DP Flat	
FRE-SCD06H-AL1/12	SC Duplex 6P Panel 1-12HP Angle left	
FRE-SCD06H-AR1/12	SC Duplex 6P Panel 1-12HP Angle right	
FRE-ST06H-FL1/6	ST/FC 6P Panel 1-6HP Flat	
FRE-ST06H-AL1/6	ST/FC 6P Panel 1-6HP Angle left	
FRE-ST06H-AR1/6	ST/FC 6P Panel 1-6HP Angle right	
FRE-ST12D-FL1/12	ST/FC 12P Panel 1-12DP Flat	

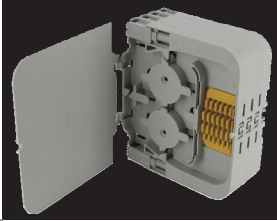
FRE-ST12D-FL13/24	ST/FC 12P Panel 13-24DP Flat	
SPLCASS-SSH-HD-6/12K	Splice Cassette Kit with HD Comb for up to 12 Splices	
SPLCASS-SSH-HD-12/24K	Splice Cassette Kit with HD Combs for up to 24 Splices	
SPLCASS-SSH-HD-18/36K	Splice Cassette Kit with HD Combs for up to 36 Splices	
SPLCASS-SSH-HD-24/48K	Splice Cassette Kit with HD Combs for up to 48 Splices	

## Modular DIN Rail Mounted Enclosure

Full range of additional accessories available including:

- Pigtails
- Simplex and duplex adapters
- MTP flat or angled cassettes
- Splicing consumables
- Termination consumables

These optional accessories can be ordered as a kit with any enclosure. Contact AFL for part numbers

## Indoor Mono Tube Fire Resistant Cable - Singlemode



### PRODUCT INFORMATION

A fire resistant mono tube cable featuring heat resistant Mica tape, glass yarns and an LSZH jacket making it suitable for use in applications such as fire alarm systems, requiring up to 120 minutes of fire resistance in accordance with IEC 60331-25.

### FEATURES & BENEFITS

- Fire resistant to IEC 60331-25 @ 750°C 120 minutes
- Heat resistant Mica tape
- Red LSZH UV resistant jacket
- Aramid glass yarns provide protection and strength
- Mono tube gel filled construction

### PHYSICAL CHARACTERISTICS

Number of Fibres	6	12
Number of Fibres per Tube	up to 12	
Number of Elements	1	
Tube/Fiber Diameter (mm)	2.8	
Nominal Cable Diameter (mm)	7.5	
Nominal Cable Weight (kg/km)	60	
Max. Tensile Strength	2.0kN	
Max. Crush Resistance	2.5kN/100mm (Long Term)	
Max Impact	10 Joules	
Min. Bending Radius	15x cable OD Installation 10x cable OD Long term	
Temperature Range (°C)	Storage: -40° to 70°C	Installation: -5° to 50°C Operation: -30° to 70°C
Waterblocking	Thixotropic Gel filled tube	
Fire Protection Material	Mica Tape	
Refract Protection	Glass Yarns	
Outer Sheath	Material: UV Resistant LSZH. Colour: Red	
Flame Retardant	IEC 60332-1	
Fire Retardant	IEC 60332-3-24	
Fire Resistance	IEC 60331-25 120 minutes @ 750°C Max Attenuation 0.5dB	

In support of our policy of continuous product improvement we reserve the right to change materials and specifications without notice. Drawings where shown, may not be to scale. Dimensions are metric and size may be approximate. Where possible data sheets including MSDS are made available on our website and apps. All products should be installed and used in accordance to manufacturer's instruction provided. Warning: products may be subject of registered designs and patents. Refer to our website or apps for terms and conditions wherever applicable.

## Indoor Mono Tube Fire Resistant Cable - Singlemode

### IDENTIFICATION

Fibre & Buffer Colour Code Chart

No.	1	2	3	4	5	6	7	8	9	10	11	12
Colour	blue	orange	green	brown	grey	white	red	black	yellow	violet	pink	aqua

Fillers are either natural (opaque) or black, jelly filled tubes (with no fibres) are also used.

### OPTICAL CHARACTERISTICS - SINGLEMODE LOW WATER PEAK

Compliant with the following standards:	ISO/IEC 11801, IEC 60793-2-50, ITU-T G.652.D	
<b>Optical Properties</b>		
Fibre Type	SM/DS2	
ITU-T Standard	G.652.D	
Mode Field Diameter	8.6-9.4um @1310nm    9.6-10.6um @1550nm	
Cladding Diameter	125.0 +/- 0.7um	
Buffer Diameter	242 +/- 7um	
<b>Max. Attenuation of Cable</b>		
@ 1310nm	0.35dB/km	
@ 1383nm	0.35dB/km	
@ 1550nm	0.25dB/km	
@ 1625nm	0.38dB/km	

### ORDERING INFORMATION

Number of Cores	SM/DS2
6	CAB-MT-06-SMFR
12	CAB-MT-12-SMFR

In support of our policy of continuous product improvement we reserve the right to change materials and specifications without notice. Drawings, where shown, may not be to scale. Dimensions are metric and size may be approximate. Where possible data sheets including MSDS are made available on our website and apps. All products should be installed and used in accordance to manufacturer's instruction provided. Warning: products may be subject of a global design and patents. Refer to our website or apps for terms and conditions on warranty.

**Fire Rated Fibre Optical Cable Colour Code**

The colour code for the fire rated ring fibre optical cables is as below.

Fibre Colour in Cable	Pig tail Colour
Blue	Blue
Green	Orange
Brown	Green
Silver / Clear	Brown
Red	Slate
Yellow	White

This is compared to a copper cable with the drop off sequence, as the cable specifications doesn't match the cable that is produced.

This is the way the entire fire fibre ring has been terminated on the University of Newcastle's Callaghan Campus as of the current date 14/03/2022.

For more information or clarification on this please contact OAS on 49401888.

UON Fire Ring Fibre – Prepared by Geoff Lane from OAS





# BARIX

---

## EXSTREAMER 1XX

IP Audio decoder with USB/Micro SD flash interface and serial port

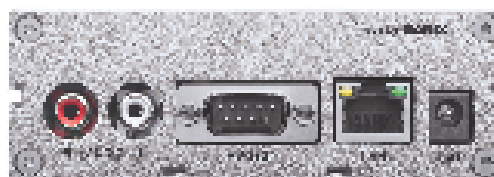
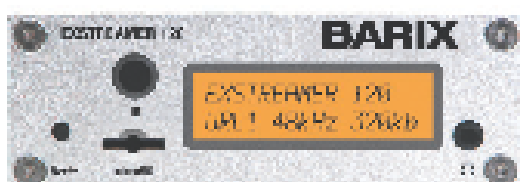

---

The Exstreamer 1xx family of products decode IP Audio streams and play out the received Audio signal to amplifiers or speakers. Supporting a large number of protocols, encoding methods and application specific firmware, the products

can be used for Broadcast, Internet Radio, as well as VoIP applications. Control and local storage Interfaces are device specific to match different use cases.

---

### Applications

- Multiroom IP Audio System Receiver
- Instore Audio Player
- Internet Radio Receiver
- SIP and IP Paging Zone Device
- Digital Annunciator, Message Player, Message Repeater
- Generic VoIP decoder for IP Paging and Announcement applications
- Commercial Audio Streaming Applications

### Features

- AACplus, MP3, Ogg Vorbis, G.711, PCM Decoding
- IP Streaming via TCP, UDP, RTP, Multicast
- Line Level Output (Stereo)
- RS-232 Serial Port
- Supply Voltage (9..30VDC, 12..24VAC)
- USB Flash Interface

## Technical Specifications

### Electrical

- 9 to 30 VDC, 12 to 24 VAC, 6 Watt max.
- 2.1mm barrel connector

### Ethernet

- 10/100Mbps Auto-negotiation
- RJ-45 connector with Integrated Link/Activity LED
- Protocols: TCP/IP, UDP, RTP, SIP, DHCP, Multicast capable, webserver for control, status and configuration

### Analog Output

- Line level output, 40..60 Ohm Impedance on RCA and 1/8" headphone jack
- Output level software controllable
- Full scale output voltage: 5.6 dBu, 4 Vpp
- Frequency response (-3dB) 10Hz ..22kHz \*
- Signal to Noise Ratio 87 dB †, THD <0.05% †

### Audio formats

- MP3 CBR/VBR, up to 320 kbps, 8..48 kHz sample freq.
- AAC-HE (AAC, AAC plus, AAC plus V2)
- Ogg Vorbis, WMA (up to version 9)
- PCM (L16, uLaw, aLaw), 8..48 kHz sample freq.
- G.711

### IR Interface

- Built-in IR receiver and IR remote control Included with Exstreamer 110 & 120 models only
- Optional external IR receiver via serial port. (IR Kit)

### Discrete I/O

- 1 Relay 24V 0.5A (normally open, 110 & 120 models only)

### RS-232 Interface

- Male 9-pin Sub-D connector
- 300..230/400 Baud asynchronous, tunneling or local control
- 12 VDC supply output for external devices (100 mA max.)

### Display

- Backlit LCD, 2x16 chars (110 & 120 models only)

### Miscellaneous

- Green and red LED for status display
- Button for reset and factory defaults

### Mechanical

- Aluminum case, 250g
- Rack and wall mountable using accessories

### Dimensions (W x H x D)

- W x H x D: 108x38x73.7mm (4.25x1.5x3.1 inch)

### Declarations of conformity

RoHS, FCC, CE, C-Tick

### MTBF (Calculated acc. MIL217F at 25°C)

- Exstreamer 100 : min. 450 000h
- Exstreamer 105 : min. 450 000h
- Exstreamer 110 : min. 450 000h
- Exstreamer 120 : min. 430 000h

### Model comparison

Model	Display	Memory	IR Relay
100	- USB	user kit	-
105	- MicroSD	user kit	-
110	yes, 2x16	USB	Included yes
120	yes, 2x16	MicroSD	Included yes

\* depends on used codec, best results @48kHz PCM

† high quality A/D supports only certain sample rates

## Environmental

### Operating Environment

0 to +40°C / 32 to 104°F \*

0 - 70% relative humidity, non-condensing

\* 0 to +50°C / 32 to 122°F for model 100/105 with rated power supply unit

### Storage Conditions

0 to +70°C / 32 to 158°F

0 - 70% relative humidity, non-condensing

## Certifications/compliant with

RoHS, FCC, CE, C-Tick

### Immunity

according to EN 55024, EN 61000-6-2

### Emissions

according to EN 55022, EN 61000-3-2, -3-3

### Product Safety

according to EN 60950

## Ordering Information

2005.9051 Exstreamer 100 EU package  
 2005.9052 Exstreamer 100 US package  
 2005.9055 Exstreamer 100 NoPSU package  
 2005.9057 Exstreamer 100 UK package

2011.9109 Exstreamer 105 EU Package  
 2011.9110 Exstreamer 105 US Package  
 2011.9111 Exstreamer 105 NoPSU package  
 2011.9112 Exstreamer 105 UK package

2007.9079 Exstreamer 110 EU package  
 2007.9080 Exstreamer 110 US package

2008.9087 Exstreamer 110 NoPSU package  
 2007.9089 Exstreamer 110 UK package

2010.9100 Exstreamer 120 EU package  
 2010.9101 Exstreamer 120 US package  
 2010.9108 Exstreamer 120 NoPSU package  
 2010.9102 Exstreamer 120 UK package

2005.9072 Wall Mounting Bracket  
 2007.9082 Barx 19" Rack mount  
 2005.9054 Cable San Audio  
 2008.9017 IR Kit (Receiver + Remote)

For commercial related questions (distributors contacts, price list, business opportunities) please contact [sales@barx.com](mailto:sales@barx.com)

For technical inquiries (problem reports, request for documentation, etc) please contact [support@barx.com](mailto:support@barx.com)

Barx AG – Ringstrasse 15A – CH-9500 Dübendorf – [info@barx.com](mailto:info@barx.com) – [www.barx.com](http://www.barx.com) – Phone: +41 43 433 22 11

© Barx AG 2015, all rights reserved. All information is subject to change without notice. All information is subject to change without notice. All mentioned trademarks belong to their respective owners and are used for reference only. Barx, Annuncicom, Exstreamer, Intersamer, SonbIP and Rfactor are trademarks of Barx A.G., Switzerland, and are registered in certain countries. Product sheet V4.4

