

BREAK OUT SESSION

Boosting innovation: Engage our PhD students.



INDUSTRY
— OPEN DAY —



Dr Jessica Allen
Senior Lecturer/DECRA Fellow
School of Engineering
The University of Newcastle



Irma Dupuis
PhD Candidate
The University of Newcastle



Ryan Mati
PhD Candidate
The University of Newcastle



Dr Kirsty Seward
HDR Program Enhancement Coordinator
Graduate Research
The University of Newcastle



Gareth Patterson
Manager, Governance and Development
Graduate Research
The University of Newcastle



GOVERNMENT INCENTIVES

Australia's Economic Accelerator

- As part of the overall \$1.6 billion investment package, **\$296 million in industry focused PhDs and fellowships** to support research commercialisation goals and drive greater university-industry collaboration.
- **1,300 industry PhDs over 10 years.**
- “PhD students will benefit from the experience of undertaking research within industry settings, creating employment pathways beyond academic roles. Industry will benefit from the opportunities to host PhD students...”

ENGAGING WITH HIGHER DEGREE RESEARCH STUDENTS: SETTING THE SCENE



INDUSTRY
— OPEN DAY —



Dr Jessica Allen

Senior Lecturer (Chemical Engineering)

DECRA Fellow (Australia Research Council)

Academic Convener (NIER Doctoral Training Centre for Energy)



NEWCASTLE INSTITUTE FOR
ENERGY AND RESOURCES





DTC

Doctoral
Training
Centres

Inspiring the next generation of industry leaders with:

- **transformative knowledge**
- **new ways of working**
- **academic solutions to industry challenges**



BACKGROUND



DTC | Doctoral Training Centres

Provides a framework for the University and Industry to work together to:

- Build multidisciplinary and multisector teams
- Create new knowledge
- Drive detailed solutions to specific business challenges
- Harness opportunities shaping these sectors
- Drive product development and commercialisation
- Increase IMPACT

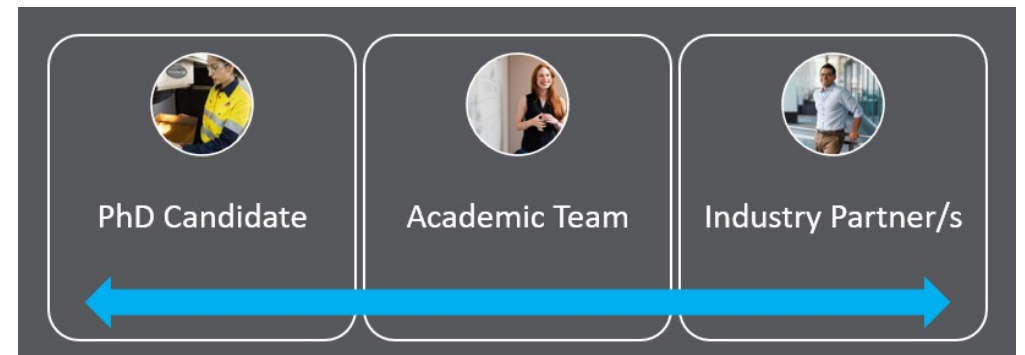
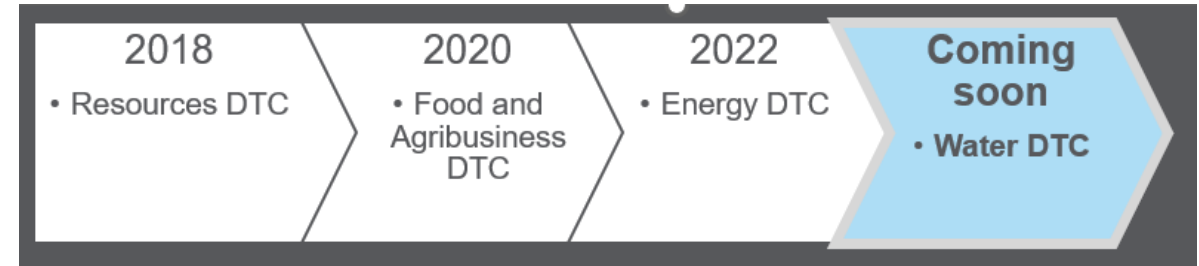

THE EMBEDDED PHD: WHAT ARE THE AIMS?

- Develop industry engaged multidisciplinary research leaders
 - ‘Work-ready’
 - Enhanced professional and technical skills
- Advance fundamental knowledge and develop key emerging technologies
- Transform innovative research into workplace practice
- Strengthen relationships between academia and industry



DTC | Doctoral
Training
Centres



BENEFITS TO INDUSTRY

- Access to UON's academic excellence and industry focused researchers
- Engage with researchers to deliver innovative solutions
- Drive commercialisation and business development
- Utilisation of University knowledge and facilities
- An established platform to support new research projects
- The creation of a network/hub for industries
- Training of potential high value future employee

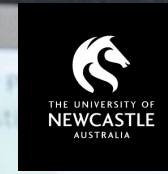

DTC | Doctoral Training Centres



DTC STUDENT PROJECT HIGHLIGHT: SAMANTHA CLARK (RESOURCES DTC)



DTC | Doctoral Training Centres

Supervisory Team: Dr Jessica Allen, Assoc. Prof. Tom Honeyands, Dr Jie Guo
Industry Supervisor: Chris Bryant (Jord International)
Industry Customer: Sugar Australia

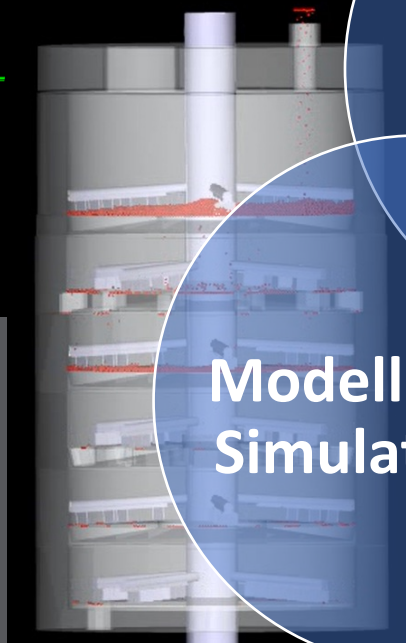
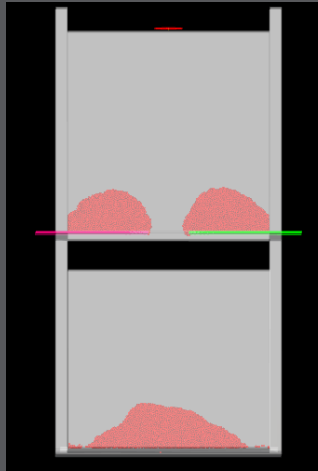

Experimental analysis

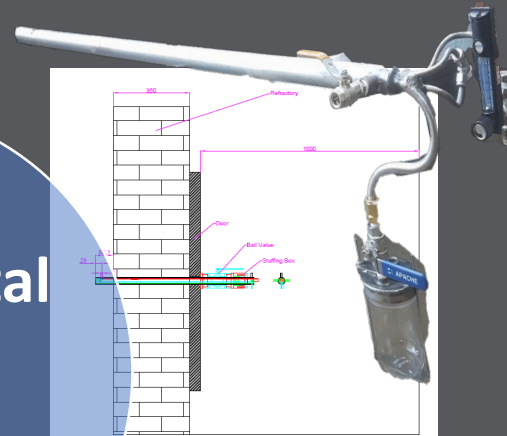

Modelling/
Simulation

Industrial Site Sampling



Tube Furnace Set-up

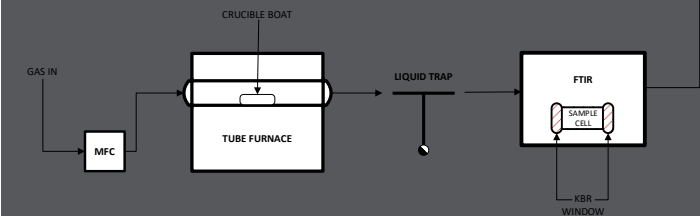

Aspen Plus Model

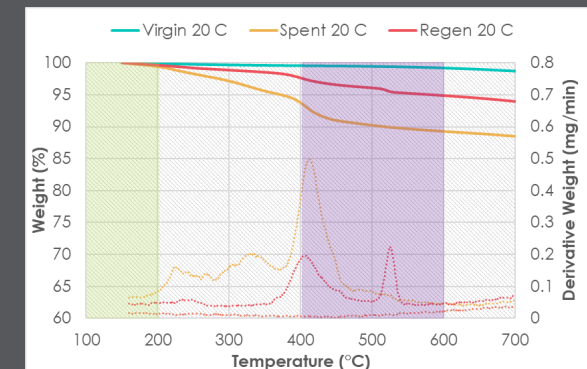
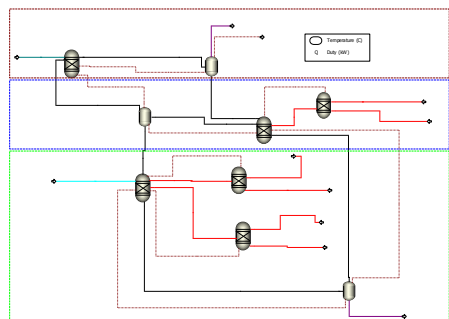

DTC STUDENT PROJECT HIGHLIGHT: JACKSON LEE (ENERGY DTC)



DTC Doctoral Training Centres

Supervisory Team: Dr Jessica Allen, Dr Noel Duffy (CSIRO),
Industry Supervisor: Mr Timothy Dawson (PV Industries)



Hon. Minister Chris Bowen,
Minister for Climate
Change and Energy, visit to
NIER July 2023

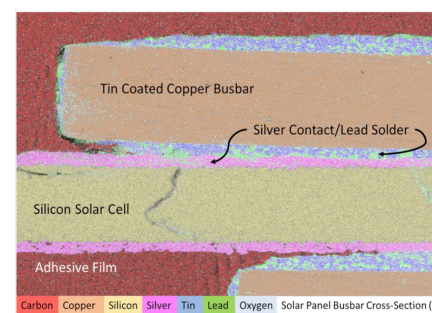
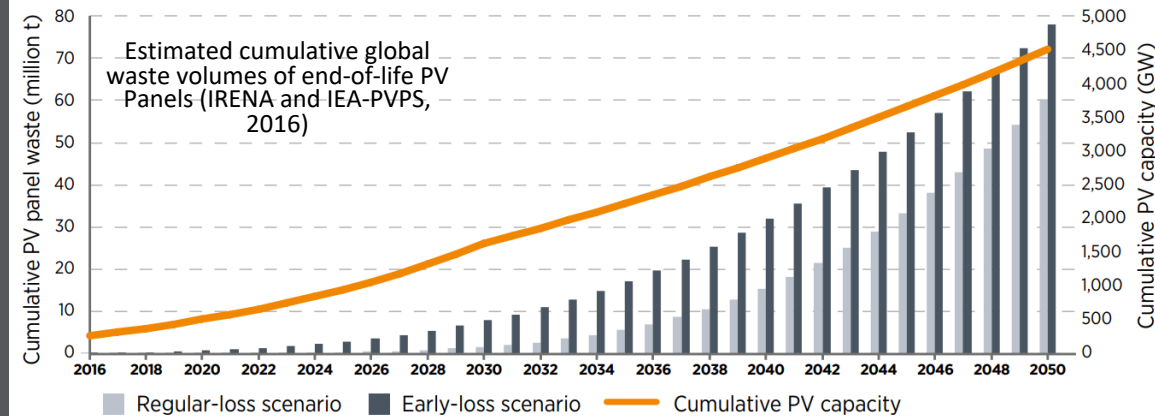

Elemental map of busbar cross-section (Jackson Lee, July 23)

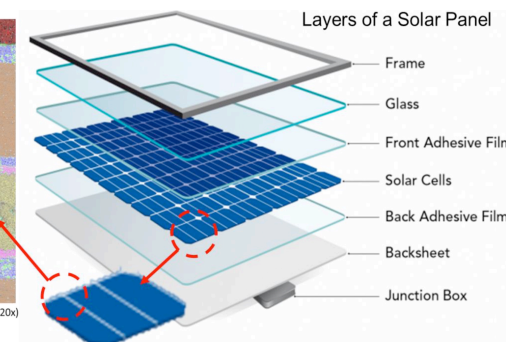

Diagrammatic representation of a solar panel (reproduced from Alejomiranda)

Separated solar panel components, Jackson Lee Aug 2023

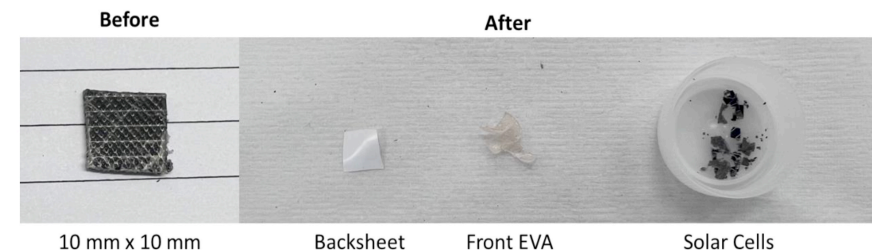

10 mm x 10 mm Backsheet Front EVA Solar Cells

IT'S WINE, TRUST ME: CONNECTED WINE PACKAGING IN THE BLOCKCHAIN ERA



INDUSTRY
— OPEN DAY —



Irma Dupuis
PhD Candidate
The University of Newcastle

Supervisors: Prof. Jamie Carlson, Prof. Lisa Toohey,
A/Prof. Tamara Bucher

Wine
Australia

laava®

MULTI-COLOR
mcc™
GLOBAL LABEL SOLUTIONS

FIRST
CREEK
HUNTER VALLEY

TAMBURLAINE
ORGANIC WINES



INDUSTRY-LED RESEARCH

- Wine fraud cost \$150-205 million in FY18/19 in Australia alone
- Complex wine supply chain and increased traceability requirements
- Premiumisation of the wine market and sustainability claims
- Opportunity to leverage blockchain traceability and engage consumers



RESEARCH IMPACT

- Understand blockchain traceability to inform the adoption of connected packaging in the wine industry
- Design smart labels that engage and inform consumers
- Present findings to industry partners and provide targeted recommendations



TOPICAL, SUSTAINED RELEASE DRUG DELIVERY PLATFORM FOR THE TREATMENT OF OCULAR PAIN



INDUSTRY
— OPEN DAY —



Ryan Mati
3rd year PhD Candidate
The University of Newcastle

Supervisor: Prof Nathan Bartlett



Health
Hunter New England
Local Health District



ABOUT THE PROJECT

Partnered with **Foray Therapeutics**, an SME supported by Brandon Capital Partners through the *Brandon BioCatalyst* life sciences investment fund.

- Foray are developing novel therapies for chronic ocular pain.
- Conducted the early pre-clinical cell-based screening of new Foray compounds.
 - Assessing 'drugability' of hit compounds
- Developing more complex disease models of the cornea in parallel for future use in ophthalmic drug development.



INTERNSHIP EXPERIENCE

*A Brandon BioCatalyst Internship at **Brandon Capital Partners***

- Completed a commercial landscape analysis for Foray Therapeutics and given the opportunity to present my findings to the investors.
- Introduced to life sciences venture capital and other commercialisation pathways that facilitate the translation of medical research.
- Improved my understanding of drug development, biomedical market analysis and how commercial opportunities in the biotechnology sector are evaluated.

EXPERIENCE

Completed a Biomedical Manufacturing Program Studentship

- Introduced to drug synthesis and development from a manufacturing perspective.
- Contributed to the synthesis of two novel compounds that were later included in pre-clinical drug screens conducted within my PhD research.

This project has provided me with unique opportunities to be involved in real world drug development processes, including insights into drug discovery, regulatory, IP and clinical strategies, and commercial analysis in the biotechnology sector.

IMPACT AS A PHD CANDIDATE

- Completion of pre-clinical drug screens **characterising >70 novel Foray compounds.**
- Completion of a commercial landscape analysis on behalf of Foray.
- Ongoing development of more complex cell models of the human cornea, **to fill the gap in *in vitro* corneal disease models available for drug development.**
- Contributions through literature reviews, interviews with key opinion leaders and clinicians, and competitor analyses.



OPPORTUNITIES TO ENGAGE OUR **PHD CANDIDATES**



INDUSTRY
— OPEN DAY —



Dr Kirsty Seward

HDR Program Enhancement Coordinator

Graduate Research

The University of Newcastle

Kirsty.Seward@newcastle.edu.au



UNITE

University of Newcastle Industry Training and Engagement

The University invites organisations to provide internships through our in-house **HDR Internship program**.

Industry partner to host PhD candidates for 3-6 months to research and perhaps solve, an industry problem designed in a project designed by the organisation.

WHAT INDUSTRY COMMITMENT IS NEEDED?

- Submit a short project outline
- Provide a mentor from the organisation who is available for the duration of the project
- Candidate placement at organisation as needed
- Fund a minimum stipend of \$3,000 per month per student.



INDUSTRY SPONSORED PHD SCHOLARSHIP



The University of Newcastle's Industry Sponsored Scholarship (ISS) program provides an opportunity for businesses to sponsor a PhD candidate (over 3.5 years*) to conduct research relevant to their challenges, be they economic, environmental or societal.

The overall cost associated with an ISS consists of two parts:

1. **The industry sponsor provides a stipend** (which via the University) is allocated to a PhD student, with the base cost to support a domestic HDR student approx. \$33,500 pa and approx. \$37,500 for an international student.
2. **A waiver for the University's tuition fees** (\$80,000 for domestic and approx. \$172,000 for an international student for a maximum 4 years of full-time candidature including time for examination) can be requested from the University once an industry sponsorship is in place. These are assessed on a case-by-case basis, noting that only in particular circumstances would the waiver not be granted.

HDR STUDENT FESTIVAL

25-29 September 2023

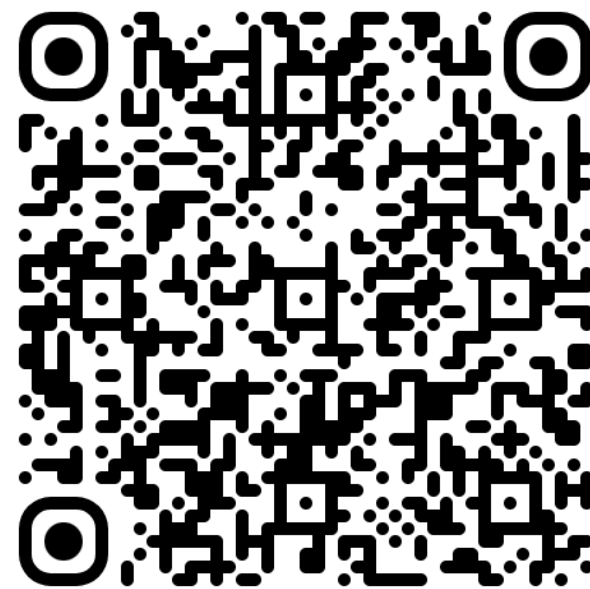

Q&A

