

CONSTRUCTION NOTES

1. STRIP THE TOPSOIL, LEVEL THE SITE AND COMPACT THE SUBGRADE.
2. COVER THE AREA WITH NEEDLE-PUNCHED GEOTEXTILE.
3. CONSTRUCT A 200mm THICK PAD OVER THE GEOTEXTILE USING ROAD BASE OR 30mm AGGREGATE.
4. ENSURE THE STRUCTURE IS AT LEAST 15 METRES LONG OR TO BUILDING ALIGNMENT AND AT LEAST 3 METRES WIDE.
5. WHERE A SEDIMENT FENCE JOINS ONTO THE STABILISED ACCESS, CONSTRUCT A HUMP IN THE STABILISED ACCESS TO DIVERT WATER TO THE SEDIMENT FENCE.

STABILISED SITE ACCESS (SD 6-14)

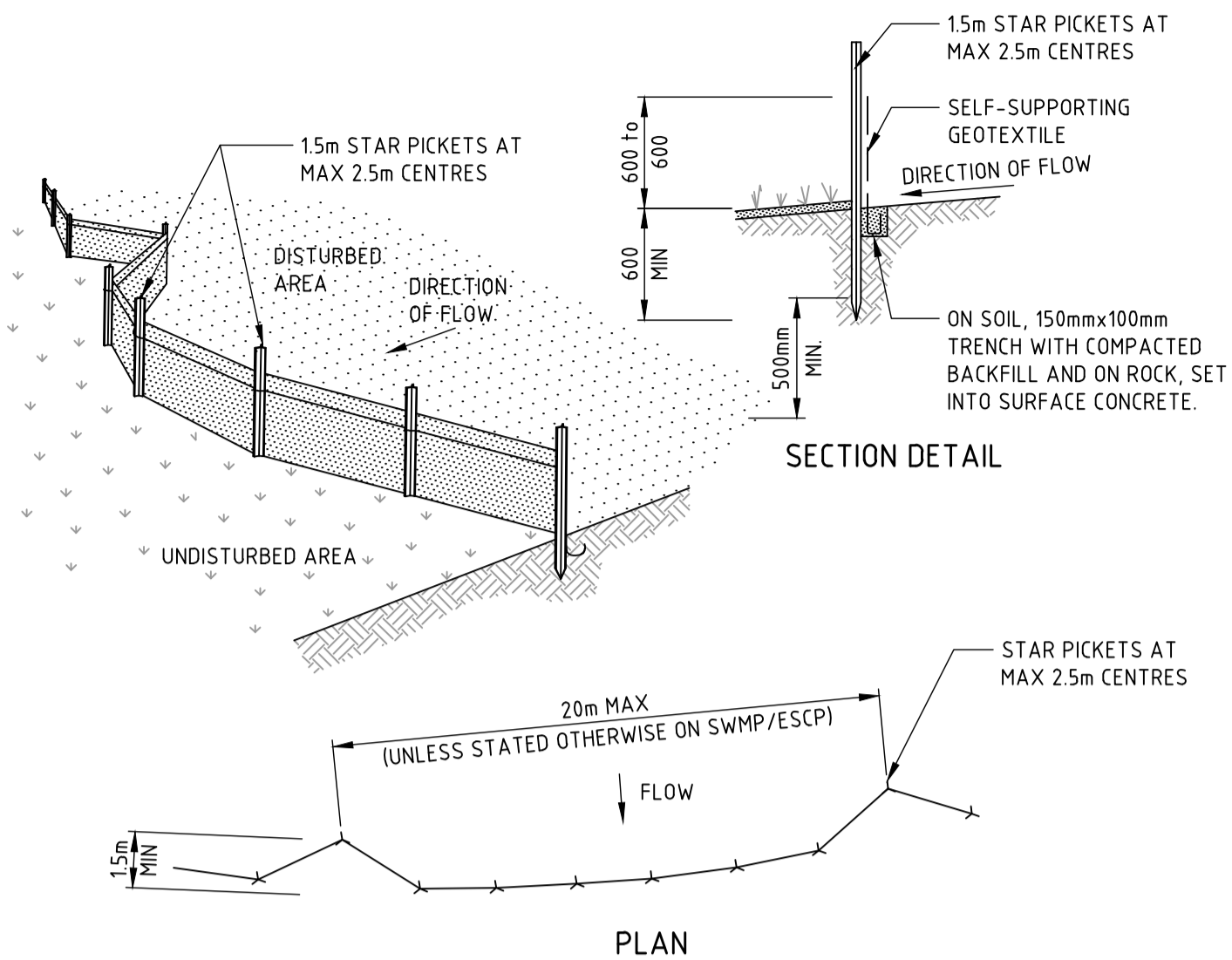

CONSTRUCTION NOTES

1. CONSTRUCT SEDIMENT FENCES AS CLOSE AS POSSIBLE TO BEING PARALLEL TO THE CONTOURS OF THE SITE, BUT WITH SMALL RETURNS AS SHOWN IN THE DRAWING TO LIMIT THE CATCHMENT AREA OF ANY ONE SECTION. THE CATCHMENT AREA SHOULD BE SMALL ENOUGH TO LIMIT WATER FLOW IF CONCENTRATED AT ONE POINT TO 50 LITRES PER SECOND IN THE DESIGN STORM EVENT, USUALLY THE 10-YEAR EVENT.
2. CUT A 150mm DEEP TRENCH ALONG THE UPSLOPE LINE OF THE FENCE FOR THE BOTTOM OF THE FABRIC TO BE ENTRENCHED.
3. DRIVE 15 METRE LONG STAR PICKETS INTO GROUND AT 2.5 METRE INTERVALS (MAX) AT THE DOWNSLOPE EDGE OF THE TRENCH. ENSURE ANY STAR PICKETS ARE FITTED WITH SAFETY CAPS.
4. FIX SELF-SUPPORTING GEOTEXTILE TO THE UPSLOPE SIDE OF THE POSTS ENSURING IT GOES TO THE BASE OF THE TRENCH. FIX THE GEOTEXTILE WITH WIRE TIES OR AS RECOMMENDED BY THE MANUFACTURER. ONLY USE GEOTEXTILE SPECIFICALLY PRODUCED FOR SEDIMENT FENCING. THE USE OF SHADE CLOTH FOR THIS PURPOSE IS NOT SATISFACTORY.
5. JOIN SECTIONS OF FABRIC AT A SUPPORT POST WITH A 150mm OVERLAP.
6. BACKFILL THE TRENCH OVER THE BASE OF THE FABRIC AND COMPACT IT THOROUGHLY OVER THE GEOTEXTILE.

SEDIMENT FENCE (SD 6-8)

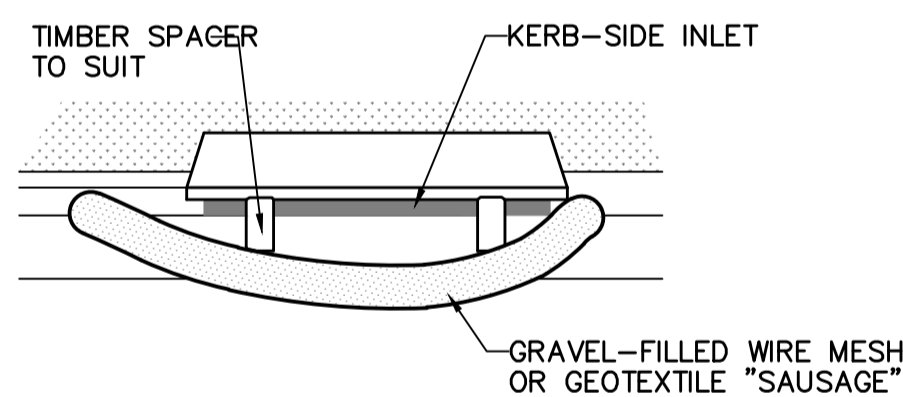

MESH AND GRAVEL INLET FILTER CONSTRUCTION NOTES:

1. FABRICATE A SLEEVE MADE FROM GEOTEXTILE OR WIRE MESH LONGER THAN THE LENGTH OF THE INLET PIT AND FILL IT WITH 25mm TO 50mm GRAVEL.
2. FORM AN ELLIPTICAL CROSS-SECTION ABOUT 150mm HIGH x 400mm WIDE.
3. PLACE THE FILTER AT THE OPENING LEAVING AT LEAST A 100mm SPACE BETWEEN IT AND THE KERB INLET. MAINTAIN THE OPENING WITH SPACER BLOCKS.
4. FORM A SEAL WITH THE KERB TO PREVENT SEDIMENT BYPASSING THE FILTER.
5. SANDBAGS FILLED WITH GRAVEL CAN SUBSTITUTE FOR THE MESH OR GEOTEXTILE PROVIDING THEY ARE PLACED SO THAT THEY CAN FIRMLY ABUT EACH OTHER AND SEDIMENT / LADEN WATERS CANNOT PASS BETWEEN.

MESH AND GRAVEL INLET FILTER

SCALE N.T.S.

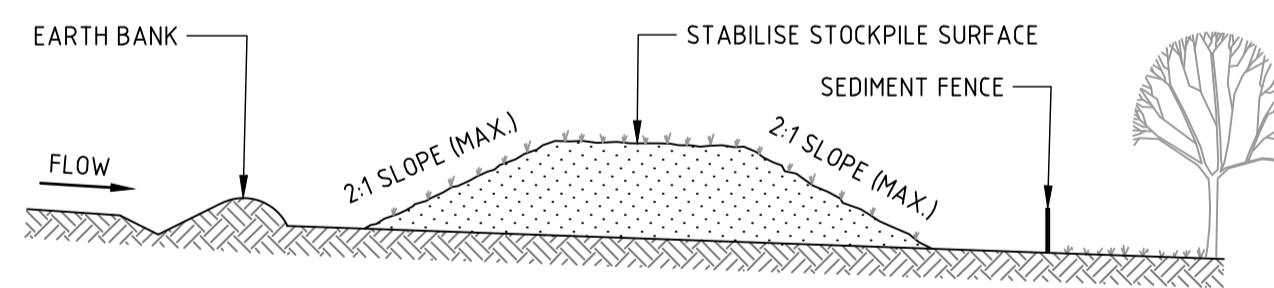

CONSTRUCTION NOTES

1. PLACE STOCKPILES MORE THAN 2m (PREFERABLY 5m) FROM EXISTING VEGETATION, CONCENTRATED WATER FLOW, ROADS AND HAZARD AREAS.
2. CONSTRUCT ON THE CONTOUR AS LOW, FLAT, ELONGATED MOUNDS.
3. WHERE THERE IS SUFFICIENT AREA, TOPSOIL STOCKPILES SHALL BE LESS THAN 2m IN HEIGHT.
4. WHERE THEY ARE TO BE IN PLACE FOR MORE THAN 10 DAYS, STABILISE FOLLOWING THE APPROVED ESCP OR SWMP TO REDUCE THE C-FACTOR TO LESS THAN 0.10.
5. CONSTRUCT EARTH BANKS (STANDARD DRAWING 5-5) ON THE UPSLOPE SIDE TO DIVERT WATER AROUND STOCKPILES AND SEDIMENT FENCES (STANDARD DRAWING 6-8) 1 TO 2m DOWNSLOPE.

STOCKPILES (SD 4-1)

VERIFIER: DRAWN: L STEEL
JOB MANAGER: C SMITH
DESIGNED: C SMITH



ISSUED FOR APPROVAL

REVISION	DESCRIPTION	ISSUED	VER'D	APP'D	DATE
1	ISSUED FOR APPROVAL	CS		CS	23.05.18

CLIENT
THE UNIVERSITY OF NEWCASTLE AUSTRALIA

ARCHITECT
DENTON CORKER MARSHALL

ALL SETOUT TO ARCHITECT'S DRAWINGS. DIMENSIONS TO BE VERIFIED WITH THE ARCHITECT AND ON SITE BEFORE MAKING SHOP DRAWINGS OR COMMENCING WORK. NORTHROP ACCEPTS NO RESPONSIBILITY FOR THE USABILITY, COMPLETENESS OR SCALE OF DRAWINGS TRANSFERRED ELECTRONICALLY.

SCALE 1:100 @ A1

NORTHROP
 Newcastle
 Suite 4, 215 Pacific Hwy, Charlestown NSW 2290
 P.O. Box 180, Charlestown NSW 2290
 Ph (02) 4943 1777 Fax (02) 4943 1577
 Email newcastle@northrop.com.au AIN 81 094 433 100

PROJECT
UoN BIO-RESOURCES FACILITY

DRAWING TITLE
EROSION AND SEDIMENT CONTROL DETAILS

JOB NUMBER
NL171955

DRAWING NUMBER
C11

REVISION
1

DRAWING SHEET SIZE = A1